

SWH GROUNDING SPLICE PLATE

Part No. EA-SW-GSP-01, EA-SW-GSP-01B

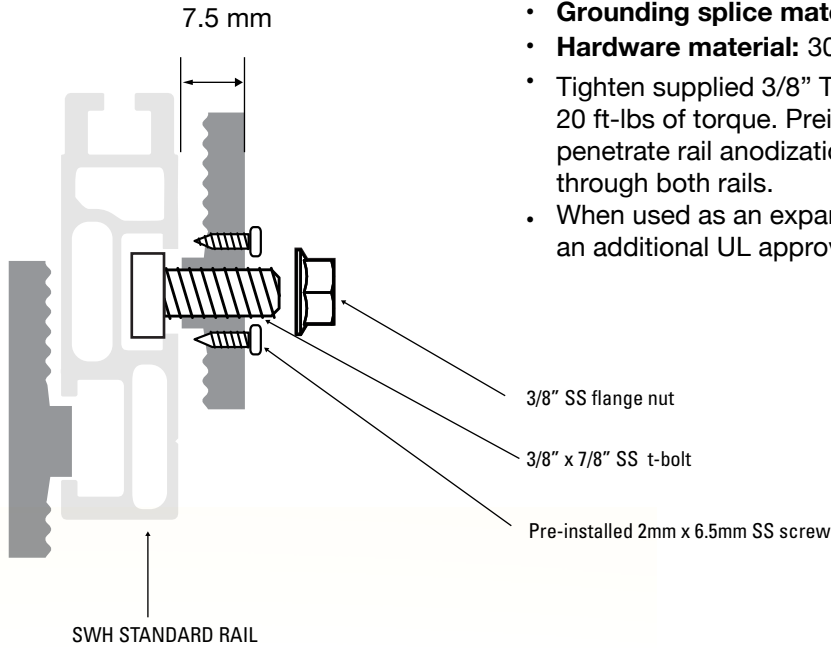

- **Conforms to UL STD 2703**
- **Grounding splice material:** 6005-T5 extruded aluminum alloy
- **Hardware material:** 304 and/or 316 stainless steel
- Tighten supplied 3/8" T-bolts and flange nuts to 20 ft-lbs of torque. Preinstalled screws will automatically penetrate rail anodization to create grounding path through both rails.
- When used as an expansion joint with one side of bolts loose, an additional UL approved splice jumper shall be used.

UL2703
LISTED



Intertek
#4009330

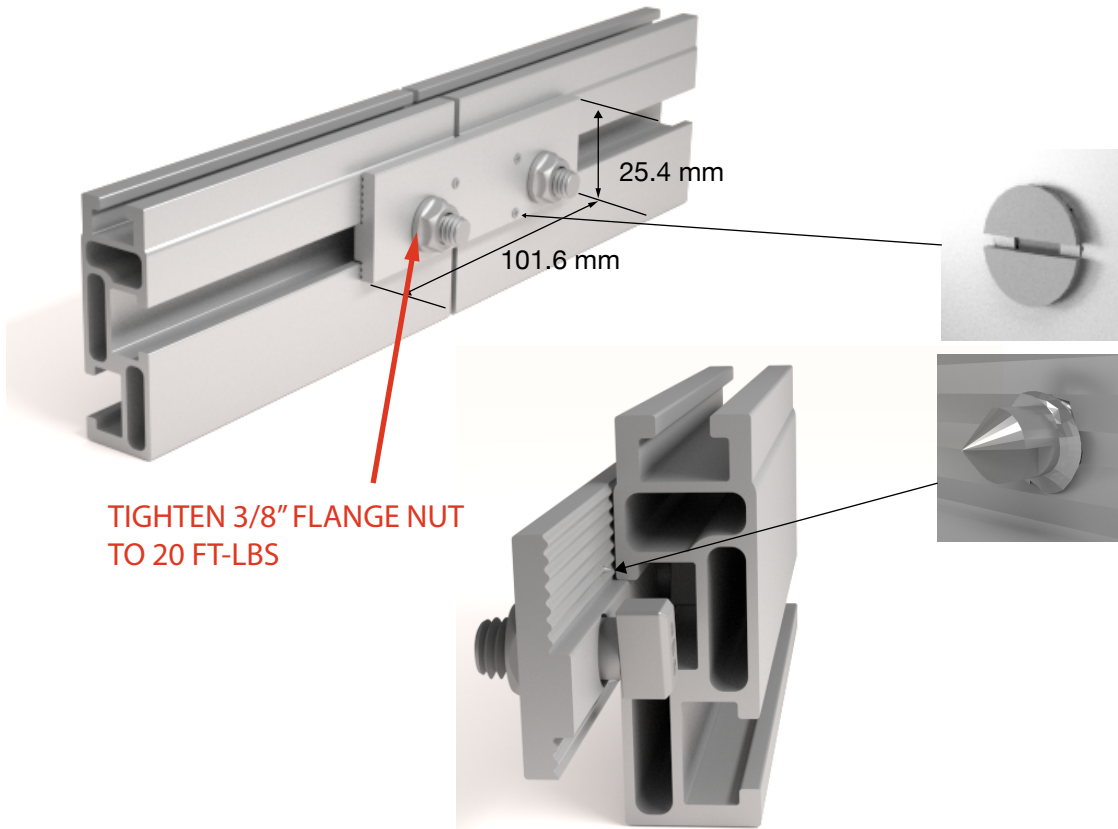

**TIGHTEN 3/8" FLANGE NUT
TO 20 FT-LBS**

Mounts to either side of SWH Standard/Ecolite Rail