

SWH GROUND MOUNT SYSTEM COMPONENTS

COMPONENTS

SWH PIPE TO RAIL ADAPTOR
MFG-PN: MR-SW-PR2, MR-SW-PR2B



Pipe to rail adaptor material:
6005-T5 extruded aluminum alloy
Finish: Clear or black anodized
Bolt & nut material: 304 stainless steel
Pipe to rail adaptor weight: 0.37 lbs
(without hardware)

SWH SLIDER BRACKET
MFG-PN: MR-SW-SL-02

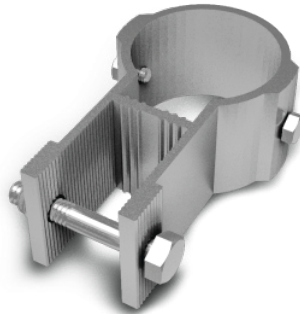

Slider bracket material:
6005-T5 extruded aluminum alloy
Finish: Clear or black anodized
Bolt & nut material: 304 stainless steel
Slider bracket weight: 0.20 lbs
(without hardware)

SWH EXTENSION LEG
MFG-PN: MR-SW-EL-120



Extension leg material:
6005-T5 extruded aluminum alloy
Finish: Clear or black anodized
Bolt & nut material: 304 stainless steel
Ext. Leg weight: 0.265lbs / foot
(without hardware)

SWH PIPE COUPLER
MFG-PN: MR-SW-SC-02

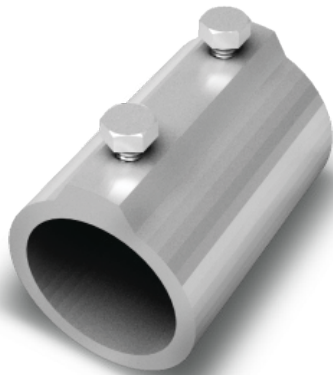

Pipe coupler material:
6005-T5 extruded aluminum alloy
Finish: Clear anodized
Bolt & nut material: 304 stainless steel
Pipe Coupler weight: 0.60 lbs
(without hardware)

NON - SWH PARTS

HOLLAENDER TEE FITTINGS
MFG-PN: MR-HC-TE-5-1.5

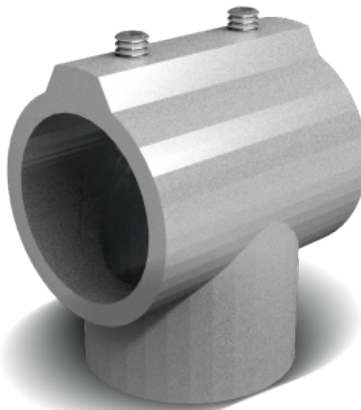

**HOLLAENDER #5 PIPE
TEE FITTINGS**

**Please consult manufacturer
specifications**

SCHEDULE 40, 21' PIPE
MFG-PN: MR-IM-PP-1521

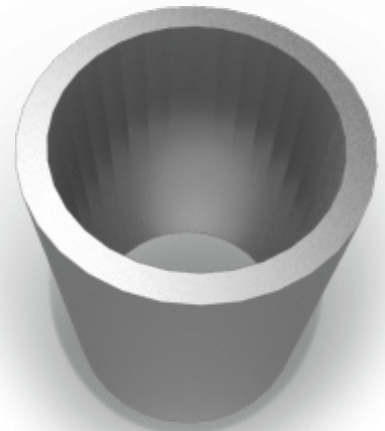

Please consult local distributor

SWH GROUND MOUNT SYSTEM

ASSEMBLY DRAWING

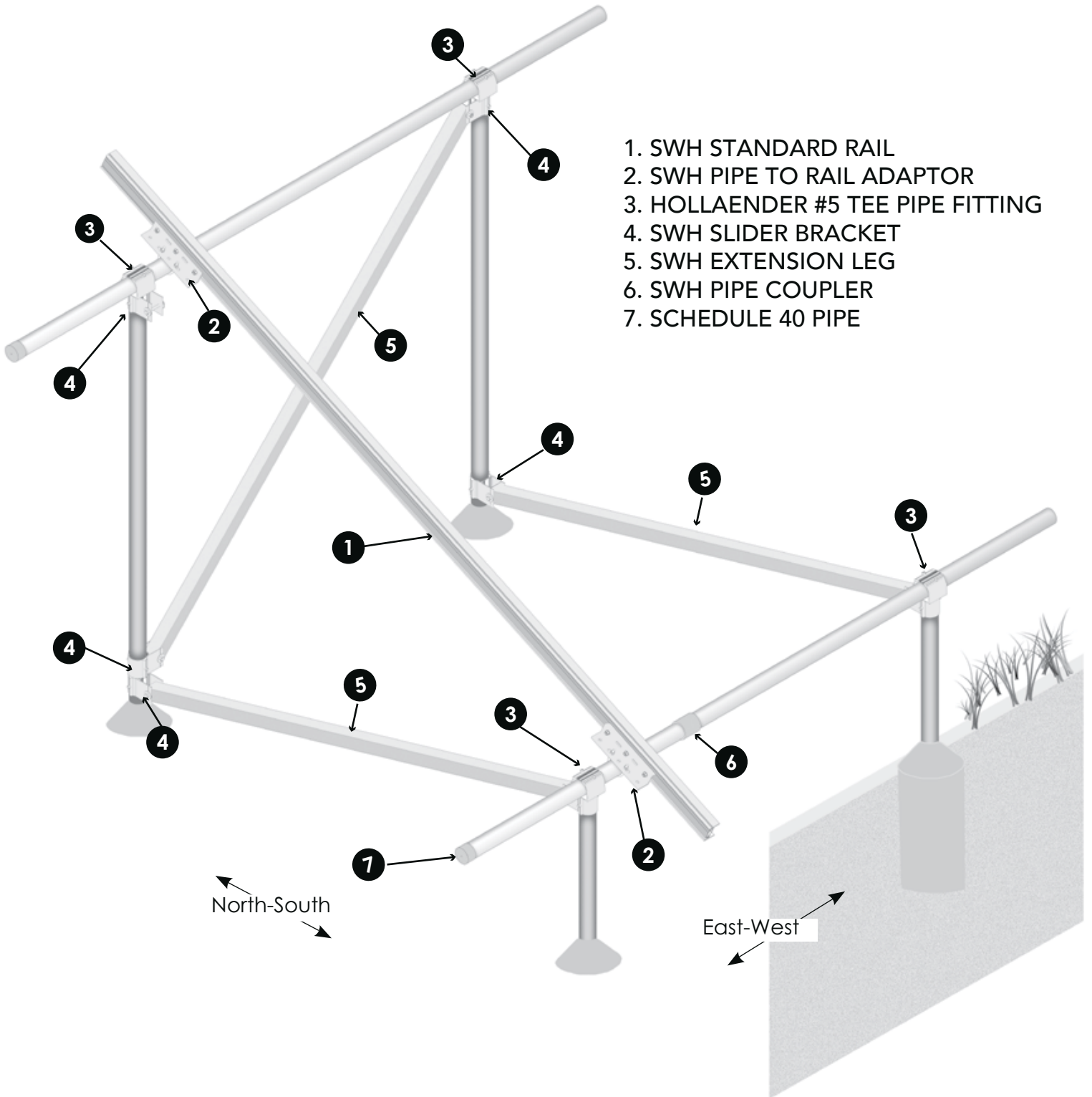

1. SWH STANDARD RAIL
2. SWH PIPE TO RAIL ADAPTOR
3. HOLLAENDER #5 TEE PIPE FITTING
4. SWH SLIDER BRACKET
5. SWH EXTENSION LEG
6. SWH PIPE COUPLER
7. SCHEDULE 40 PIPE

