

SWH Grounding End Clamp

Part No. EA-SW-GED-33, EA-SW-GEC-35,
EA-SW-GEK-40, EA-SW-GEF-45,
EA-SW-GEE-50

- **End clamp material:** 304/316 stainless steel
- **Bolt & nut material:** 304/316 stainless steel
- Assemble mid clamp with one 1/4" Grounding T-bolt and one 1/4"-20 ASTM F594 serrated flange nut
- Use anti-seize and tighten to 8 ft-lbs of torque

UL2703
LISTED



Intertek
#4009330

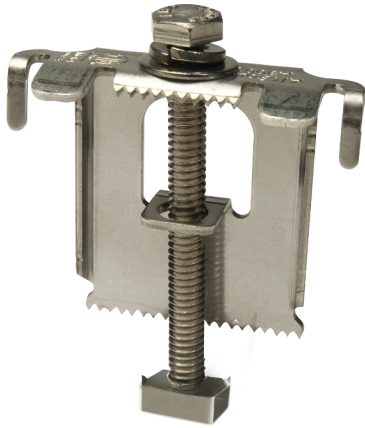

| MODEL # | T-BOLT LENGTH | MODULE HEIGHT |
|--------------|---------------|---------------|
| EA-SW-GED-33 | 50mm | 33mm |
| EA-SW-GEC-35 | 50mm | 35mm |
| EA-SW-GEK-40 | 60mm | 40mm |
| EA-SW-GEF-45 | 60mm | 45mm |

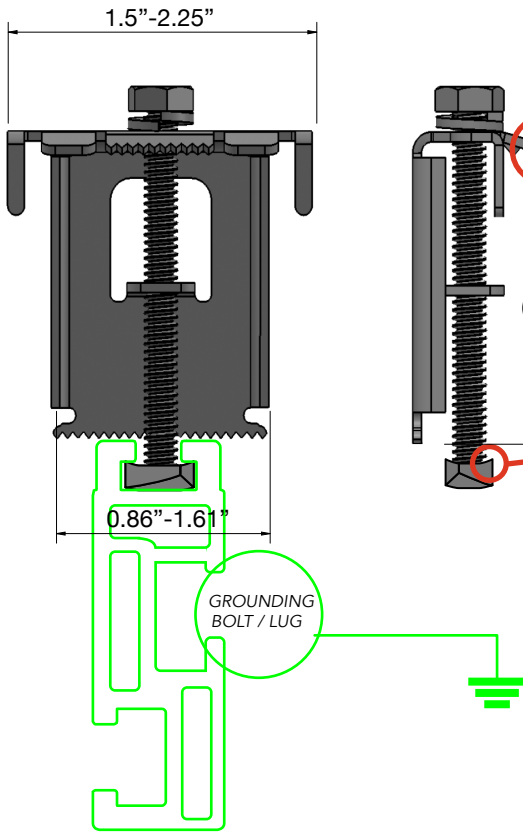

*NOT TO SCALE

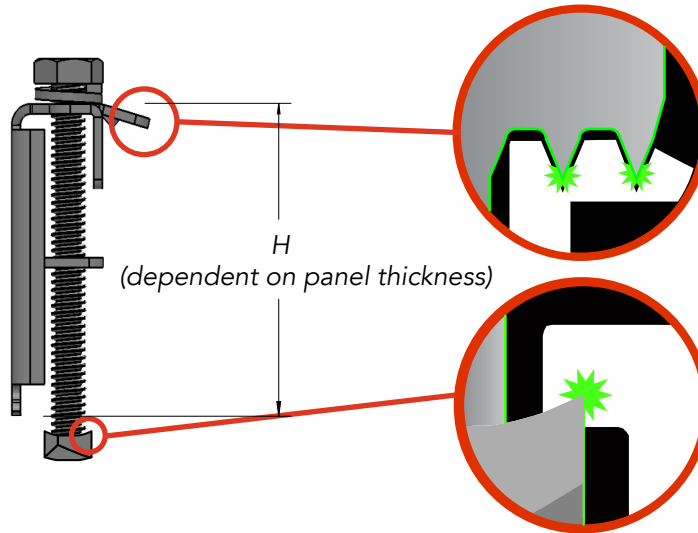

SWH stainless steel end clamp penetrates solar module frame anodization to create grounding path.

SWH stainless steel grounding T-bolt penetrates solar rail anodization to create grounding path.

