

i. Installer's Responsibilities

Please review this manual thoroughly before installing your SWH solar racking system. This manual provides (1) supporting documentation for building permit applications relating to SWH solar racking system, and (2) planning and assembly instructions for SWH products. When installed in accordance with this manual, SWH PV Mounting system will be structurally adequate and will meet the structural requirements of the IBC 2012, ASCE 7-10 and California Building Code 2013 (collectively referred to as "the Code"). Solar Warehouse also provides a limited warranty on SWH products as attached to the end of this manual.



THE INSTALLER IS SOLELY RESPONSIBLE FOR:

- Complying with all applicable local or national building codes, including any that may supersede this manual;
- Ensuring that SWH and other products are appropriate for the particular installation and the installation environment;
- Ensuring that the roof, its rafters, connections, and other structural support members can support the array under all code level loading conditions (this total building assembly is referred to as the building structure);
- Using only SWH parts and installer-supplied parts as specified by SWH (substitution of parts may void the warranty and invalidate the letters of certification in all SWH publications);
- Ensuring that lag screws have adequate pullout strength and shear capacities as installed;
- Verifying the strength of any alternate mounting used in lieu of the lag screws;
- Maintaining the waterproof integrity of the roof, including selection of appropriate flashing;
- Ensuring safe installation of all electrical aspects of the PV array;
- Ensuring correct and appropriate design parameters are used in determining the design loading used for design of the specific installation. Parameters, such as snow loading, wind speed, exposure and topographic factor should be confirmed with the local building official or a licensed professional engineer.
- Ensuring all warning labels requirements are met per latest National Electrical code (NEC), International Fire Code (IFC), and/or Cal Fire Code.
- PV system should be inspected periodically. Any loose components or fasteners found shall be tightened immediately. If corrosion is found replace affected components immediately.
- Provide an appropriate method of direct-to-earth grounding according to the latest edition of the National Electrical code including NEC 250: Grounding and Bonding, and NEC 690: Solar Photovoltaic Systems.
- This racking system may be used to ground and/or mount a PV module complying with UL 1703 only when the specific module has been evaluated for grounding and/or mounting in compliance with the included instructions. See module compatibility section.

TABLE OF CONTENTS

- i. Installer’s Responsibilities 2
- [1.1] Ratings / Certification Details2
- [1.2] SWH Solar Racking Components4
- [1.3] Installing SWH with Top Mounting Clamps6
- [1.4.1] Planning Your SWH Racking Installations7
- [1.4.2] Laying Out L-Brackets8
- [1.4.3] Laying Out Standoffs9
- [1.4.4] Installing Tile Struts10
- [1.4.5] Installing Flashed L Feet11
- [1.4.6] Installing Roof Bar.....12
- [1.4.7] Installing Roof Hook13
- [1.5.1] Installing SWH Rails and Splices.....14
- [1.5.2] Installing the Modules15
- [1.5.3] Grounding Path Diagram and Components.....17
- [1.6] Installer Warning and Notice19
- [1.7] Mechanical Loading Specifications and Module Compatibility.....21
- Warranty Sheet22

1.1 RATINGS / CERTIFICATION DETAILS

SWH solar racking system has been evaluated by Intertek Testing Services NA (ETL) and Listed to UL Standard 2703 for Grounding/Bonding, Mechanical Loading, and Fire Classification.

A GROUNDING / BONDING

This racking system may be used to ground and/or mount a PV module complying with UL 1703 only when the specific module has been evaluated for grounding and/or mounting in compliance with the included instructions.

- Conforms to UL 2703 (2015) Standard for Mounting Systems, Mounting Devices, Clamping/ Retention Devices, and Ground Lugs for Use with Flat-Plate Photovoltaic Modules and Panels.
- Conforms to UL 467 for Safety Grounding and Bonding Equipment
- Max Over-current Protective Device (OCPD) Rating: 20A
- Ground Conductor Rating: 6-10 AWG, bare copper. May require conduit protection for conductors smaller than 6 AWG according to NEC.

B MECHANICAL LOADING

The Solar Warehouse system is listed for mechanical loading for different load ratings depending on the mounting configuration and PV module installed. For more details on the mechanical loading details see the Mechanical Loading Specifications section.

- Mechanical Load Rating: exceeds minimum requirements of the standard (10 PSF downward, 5 PSF upward, 5 PSF lateral). Actual system structural capacity is defined by PE stamped certification letters.
- Solar Warehouse engineered systems should only be used with Solar Warehouse components and hardware.
- Any applications outside of those specified in this Installation Manual and the Design & Engineering guide may void the warranty and structural certification.
- The UL Listing covers mechanical load ratings for the various span lengths, module orientations and positive, negative, and side load ratings. These values can be found in the Mechanical Loading Specifications.
- Solar Warehouse recommends a periodic re-inspection of the completed installation for loose components, loose fasteners, and any corrosion, such that if found, the affected components are to be immediately replaced.

1.1 RATINGS / CERTIFICATION DETAILS

SWH solar racking system has been evaluated by Intertek Testing Services NA (ETL) and Listed to UL Standard 2703 for Grounding/Bonding, Mechanical Loading, and Fire Classification.

C CLASS A SYSTEM FIRE RATING PER UL 1703

- Steep slope roof with Module Types 1 and 2.
- Any module-to-roof gap is permitted, with no perimeter guarding required. This rating is applicable with any third-party attachment.
- Class A rated PV systems can be installed on Class A, B, and C roofs without affecting the roof fire rating.

D METHOD OF MARKING

UL Listing stamped at the end of every rail.

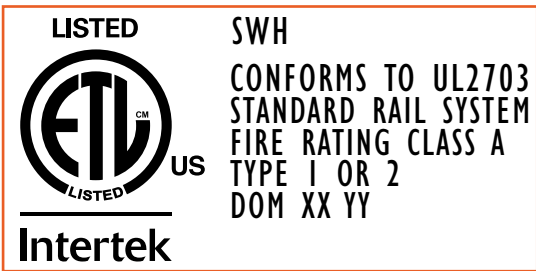

METHOD OF MARKING IS COIN STAMPED
 "XX" DENOTES WEEK OF MANUFACTURE OUT OF 52 WEEKS IN A YEAR
 "YY" DENOTES LAST TWO DIGITS OF THE YEAR OF MANUFACTURE



SWH STANDARD RAIL SAMPLE SHOWN

1.2 SWH SOLAR RACKING COMPONENTS

⚡ INTEGRATED BONDING PER UL 2703

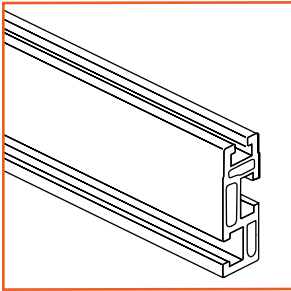

Standard Rail

Used to support PV modules. Aluminum extrusion, anodized silver or black.

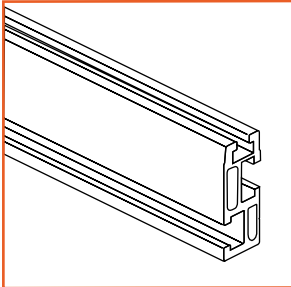

Ecolite Rail

Used to support PV modules. Aluminum extrusion, anodized silver or black or mill finish.

(Not fire rated)

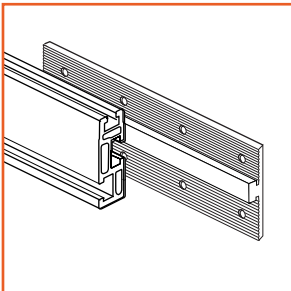

⚡ Rail Splice Bar-For Standard Rail Only

Joins and aligns rail sections into single length of rail. It can form either a rigid or thermal expansion joint, 8 inches long, predrilled. Aluminum extrusion, anodized silver or black.

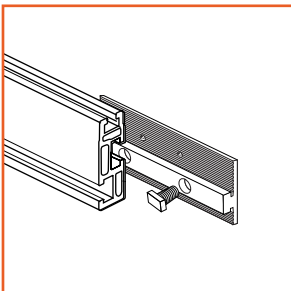

⚡ Self Grounding Splice Plate

Bonds and aligns rail sections into single length of rail with supplied 3/8" x 7/8" T-bolt. It can form either a rigid or thermal expansion joint, 4" long, predrilled. Aluminum extrusion, anodized silver or black or mill finish.

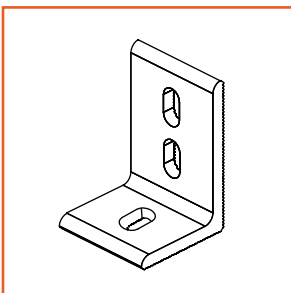

⚡ L-Bracket

Use to secure rails either through roofing material to building structure or roof attachments. Refer to Load Tables for spacing. Short 2"x2" or long 2"x3". Aluminum extrusion, anodized silver or black or mill finish.

GROUNDING COMPONENTS

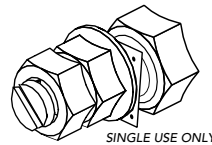

SINGLE USE ONLY

⚡ Grounding Bolt - Stainless steel bolt and grounding washer bond rail to grounding wire.

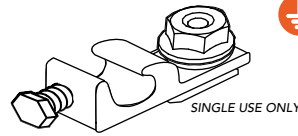

SINGLE USE ONLY

⚡ Grounding Lug - Tin-Copper plated aluminum lug for bonding rail to grounding wire.

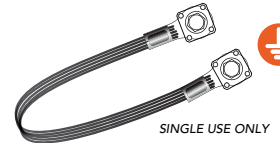

SINGLE USE ONLY

⚡ Bonding Jumper - Tin-Copper wire for bonding two rail sections to one another.



METHOD A

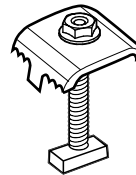

⚡ Self Grounding Mid Clamp - Stainless steel, 3 sizes available.

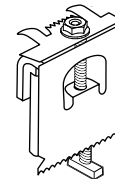

⚡ Self Grounding End Clamp - Stainless steel, different sizes available.



METHOD B

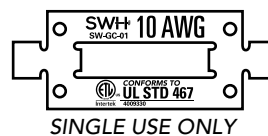

SINGLE USE ONLY

⚡ Grounding Clips - Stainless steel clips bond panels to rails. Place under panels and mid clamps. Place under end clamps.

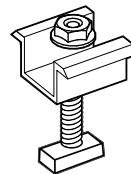

Mid Clamp - Top mounting clamp one size fits all. Anodized silver or black.

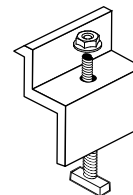

End Clamp - Top mounting clamp. Different sizes available. Anodized silver or black.

⚠ Installer supplied materials:

- Waterproof roofing sealant/caulking
- Roof flashing

All SWH end and mid clamps are intended for MULTIPLE USES at same or different module frame locations

SWH grounding washer and clip are intended for SINGLE USE ONLY. Functionality may be compromised if reused.

1.2 SWH Solar Racking Components

ROOF ATTACHMENT OPTIONS

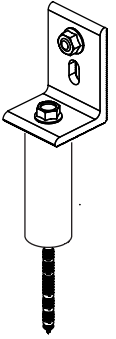

Standoff [1.4.3], pg. 8
 Use to mount rail on composite shingle or tile roofs. Available in 3.5", 5" & 8" heights. Outside diameter is 1". Comes with 5/16"x 3.5" lag post and 3/8"x1" hex bolt and 3/8" flat washer.

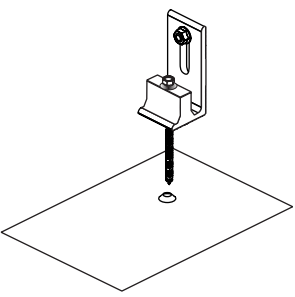

Flashed L Feet [1.4.5], pg.10
 Use to mount rail on composite shingle roof. Comes with 12"x10" steel flashing, EPDM sealing gasket and 5/16" x 5" lag bolt. (Not fire rated)

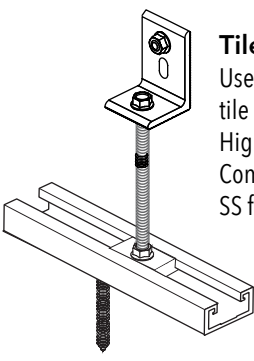

Tile Strut [1.4.4], pg. 9
 Use to mount rail on Spanish tile or flat concrete tile roof. Low Profile version has 3/4" base height. High Profile version has 1" base height. Comes with 4" or 6" all thread rod, 2"x2" SS flashing, and additional hardware.

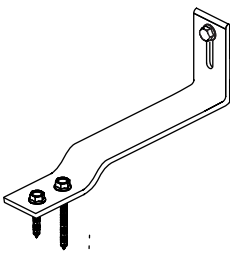

Roof Bar [1.4.6], pg. 11
 Use to mount rail on flat concrete tile roof. Stainless steel hardware included.

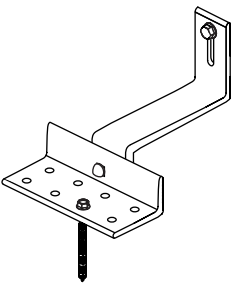

Roof Hook [1.4.7], pg. 12
 Use to mount rail on Spanish tile or flat concrete tile roof. Stainless steel hardware included.



Installer supplied materials:

- Waterproof roofing sealant/caulking
- Roof flashing (when required)

Table 11: Lag- pull-out (withdrawal) capacities (lbs) in typical roof lumber (ASD)

	<i>5/16" lag screw* specifications</i>	
	<i>Specific gravity</i>	<i>per inch thread depth</i>
<i>Douglas Fir, Larch</i>	<i>0.50</i>	<i>266</i>
<i>Douglas Fir, South</i>	<i>.46</i>	<i>235</i>
<i>Engelmann Spruce, Lodgepole Pine¹</i>	<i>.46</i>	<i>235</i>
<i>Hem, Fir, Redwood (close grain)</i>	<i>.43</i>	<i>212</i>
<i>Hem, Fir (North)</i>	<i>.46</i>	<i>235</i>
<i>Southern Pine</i>	<i>.55</i>	<i>307</i>
<i>Spruce, Pine, Fir</i>	<i>.42</i>	<i>205</i>
<i>Spruce, Pine, Fir²</i>	<i>.50</i>	<i>266</i>

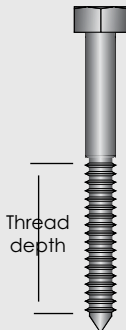

Sources: American Wood Council, NDS 2005, Table 11.2a, 11.3.2A.

- Notes:**
- (1) Thread must be embedded in the side grain of a rafter or other structural member integral with building structure.
 - (2) Lag bolts must be located in the middle third of the structural member.
 - (3) These values are not valid for wet service.
 - (4) This table does not include shear capacities. If necessary, contact a local engineer to specify lag bolt size with regard to shear forces.
 - (5) Install lag bolts with head and washer flush to surface (no gap). Do not over-torque.
 - (6) Withdrawal design values for lag screw connections shall be multiplied by applicable adjustment factors if necessary. See Table 10.3.1 in the American Wood Council NDS for Wood Construction.

**Use flat washers with lag screws.*

1.3 Installing SWH with top mounting clamps

This section covers SWH racking assembly where the installer has elected to use top mounting clamps to secure modules to the rails. It details the procedure for flush mounting SWH systems to a pitched roof.

Figure 5. Exploded view of a flush mount installation with L-bracket

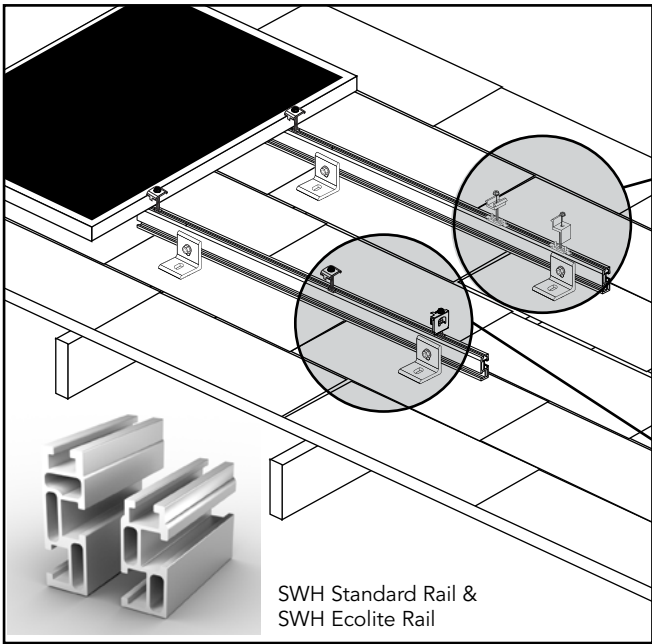

STANDARD MID CLAMP & END CLAMP

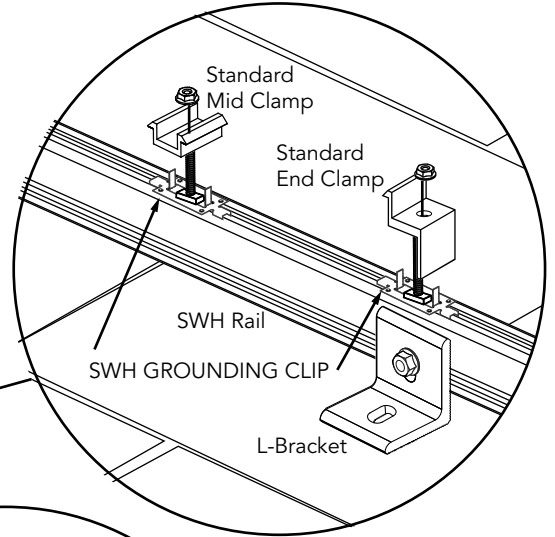

SELF-GROUNDING MID CLAMP & END CLAMP

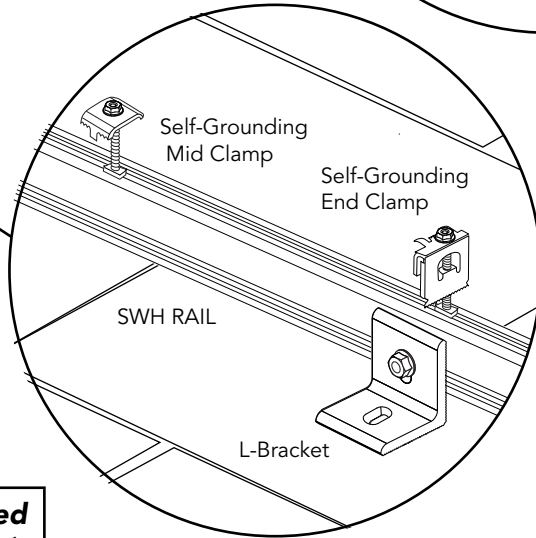
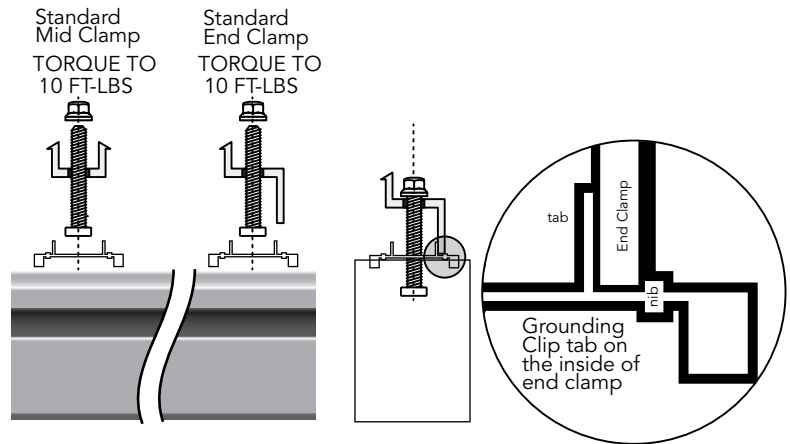



TABLE 12. Wrenches and Torque Values

	Wrench Size	Recommended Torque (ft-lbs)
1/4" hardware*	7/16"	8 * ⚠
3/8" hardware**	9/16"	20

- *SWH Grounding Lug- Tighten 1/4" flange nut to 8 ft-lbs. Tighten 1/4" wire terminal screw to 2 ft-lbs
- **SWH Grounding Bolt- Tighten INNER 3/8" Hex nut to 9 ft-lbs Tighten OUTER 3/8" hex nut to 2 ft-lbs

SEE GROUNDING PATH DIAGRAM pg. 16





All SWH self grounding end and mid clamps are intended for MULTIPLE USES at same or module frame locations.

*All top down clamps must be installed with anti-seize to prevent galling and provide uniformity in clamp load. Solar Warehouse recommends Silver Grade Loctite Anti-Seize Item numbers: 38181, 80209,76732,76759,76764, 80206, and 76775, or equivalent. 1/4" - 20 hardware used in conjunction with top down clamps must be installed to 10 ft-lbs of torque. In addition, once the hardware are secured and integrity verified, it is recommended that thread lock be applied.

1.4.1 Planning your SWH installations

The installation can be laid out with rails parallel to the rafters or perpendicular to the rafters. Note that SWH rails make excellent straight edges for doing layouts. Center the installation area over the structural members as much as possible. Leave enough room to safely move around the array during installation. Some building codes require minimum clearances around such installations, and the user should be directed to also check 'The Code'.

The width of the installation area equals the length of one module.

The length of the installation area is equal to:

- the total width of the modules,
- plus 1/4 inch for each space between modules for self-grounding mid clamp
- plus 3 inches (1½ inches for each pair of self-grounding end clamps).

Figure 6. Rails may be placed parallel or perpendicular to rafters.

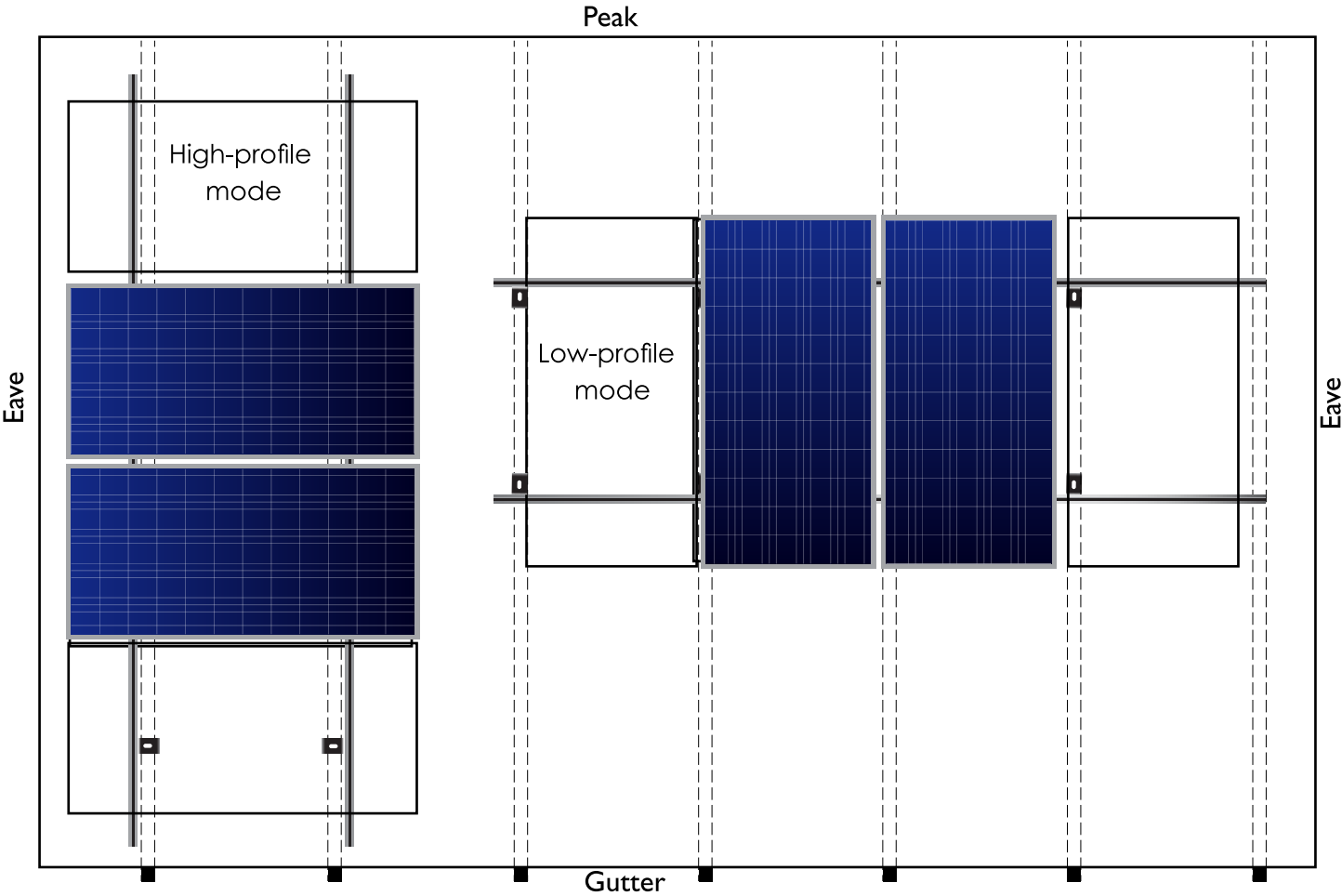

Rail cantilever/overhang span shall NOT exceed 25% of footing attachment spacing

1.4.2 Laying out L-brackets

L-Brackets can be used for attachment through existing roofing material, such as asphalt shingles or sheathing to the building structure.

Use **Figure 7** or **8** below to locate and mark the position of the L-bracket lag screw holes within the installation area.

If multiple high profile rows are to be installed adjacent to one another, it is not likely that each row will be centered above the rafters. Adjust as needed, following the guidelines in **Figure 8** as closely as possible.

Figure 7. Layout with rails perpendicular to rafters.

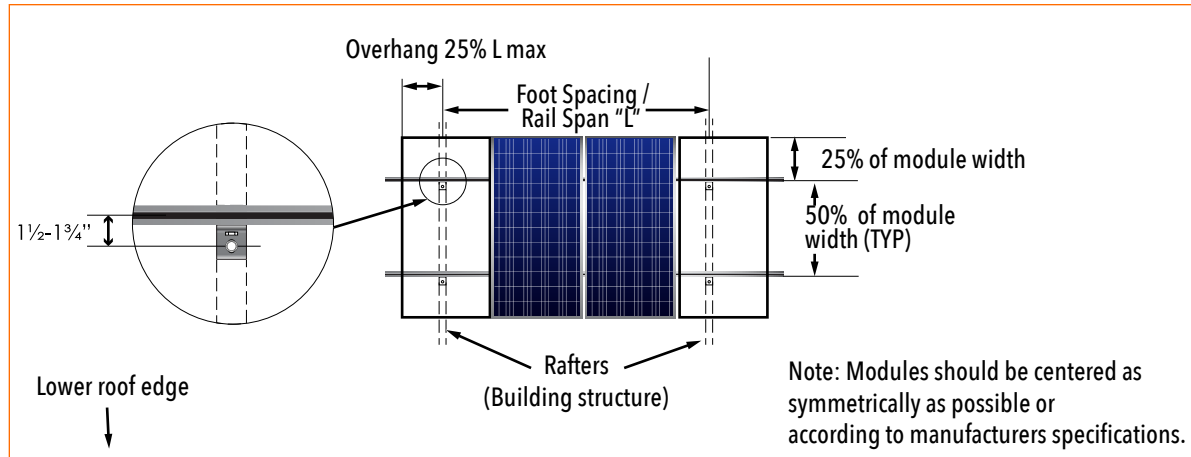

Installing L-bracket:

Drill 3/16" pilot holes through the roof into the center of the rafter at each L-bracket lag screw hole location. Squirt sealant into the hole, and on the shafts of the lag screws. Seal the underside of the L-bracket with a suitable sealant. Consult with the company providing the roofing warranty. Securely fasten the L-bracket to the roof with the lag screws. Ensure that the L-bracket face as shown in **Figure 7** and **8**. For greater ventilation, the preferred method is to place the single-slotted square side of the L-bracket against the roof with the double-slotted side perpendicular to the roof. If the installer chooses to mount the L-bracket with the long leg against the roof, the bolt slot closest to the bend must be used.

Figure 8. Layout with rails parallel to rafters

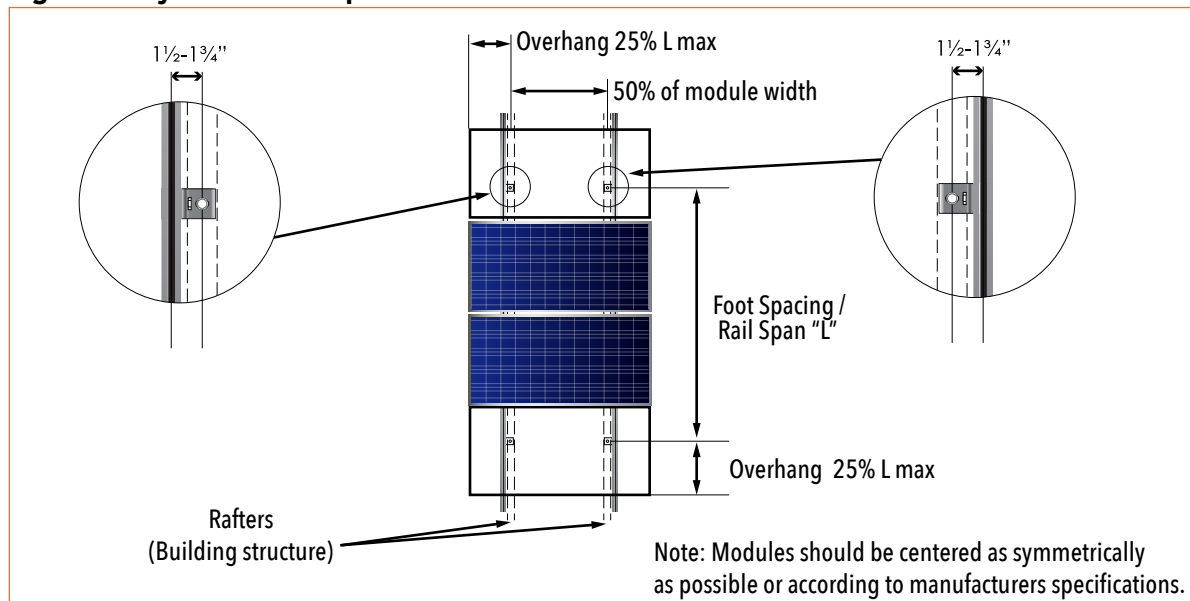

1.4.3 Layout out standoffs

Standoffs (Figure 9) are used to increase the height of the array above the surface of the roof. Pair each standoff with a flashing to seal the lag bolt penetrations to the roof. Use Figure 10 or 11 to locate and mark the location of the standoff lag screw holes within the installation area. Remove the tile or shake underneath each standoff location, exposing the roofing underlayment. Ensure that the standoff base lies flat on the underlayment, but remove no more material than required for the flashings to be installed properly. The standoffs must be firmly attached to the building structure.

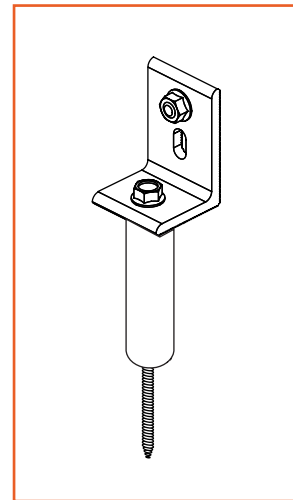

Figure 9. Standoff in conjunction with an L-Bracket.

If multiple high-profile rows are to be installed adjacent to each other, it may not be possible for each row to be centered above the rafters. Adjust as needed, following the guidelines of Figure 11 as closely as possible.

Installing Standoffs:

Drill 3/16 inch pilot holes through the underlayment into the center of the rafters at each standoff location. Apply sealant to the hole. Securely fasten 5/16" lag screw with thread top.

SWH aluminum standoffs (1" O.D.) are designed for collared flashings. Install and seal flashings and standoffs using standard building practices or as the company providing roofing warranty directs.

Figure 10. Layout with rails perpendicular to rafters

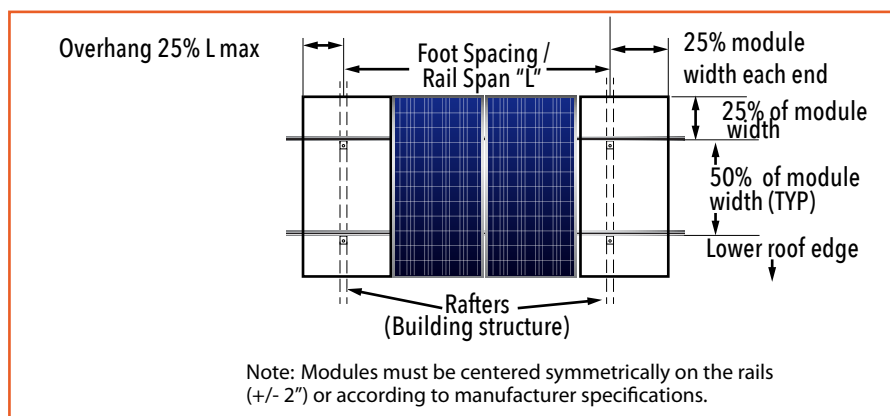
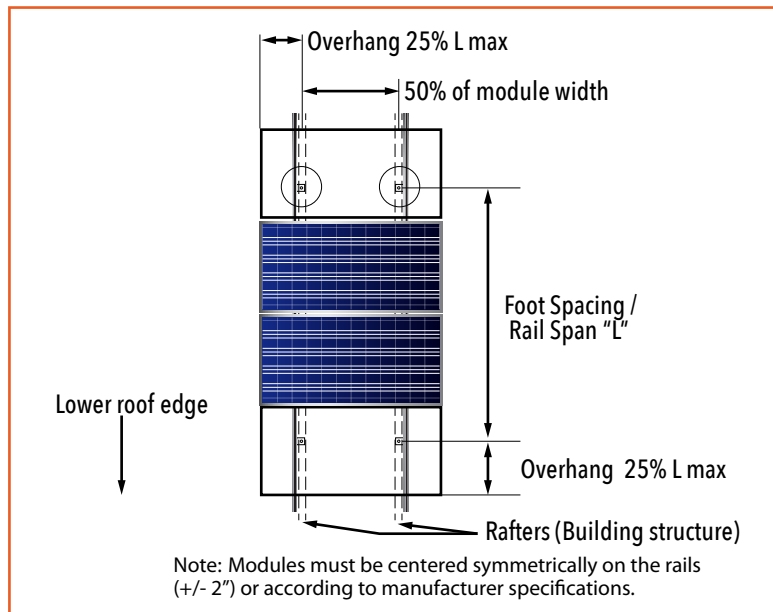
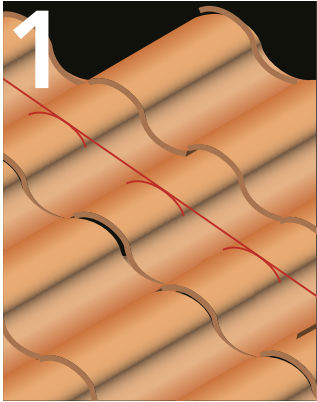

Figure 11. Layout with rails parallel to rafters.



1.4.4 Tile Strut Installation



STEP 1: Select a tile above roof rafter and chalk line.

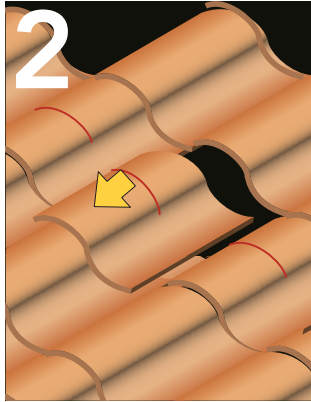

STEP 2: Remove the tile by pushing and pulling the tile, usually held in place by a small nail.

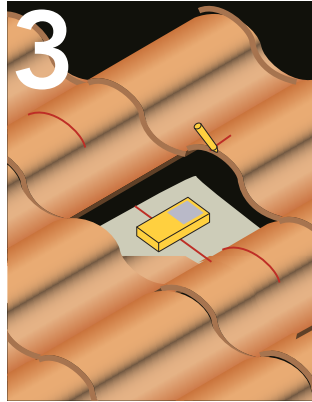

STEP 3: Use an electric stud finder to locate the rafter center. Mark a reference point on the tile above.

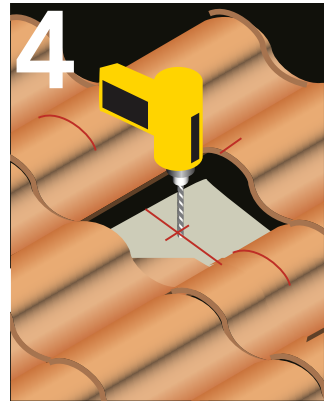

Step 4: Drill several holes to locate the exact center. A 3/16" pilot hole drill bit is recommended.

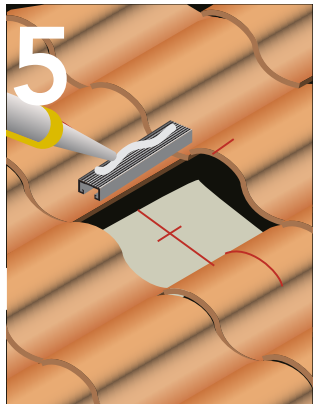

STEP 5: Insert the lag bolt and washer through the Tile Strut and apply fresh sealant

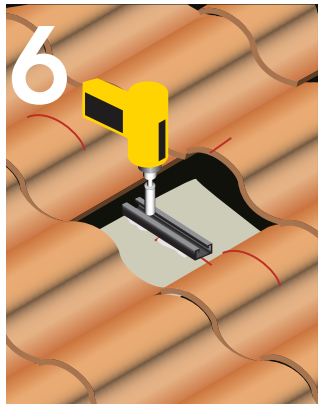

STEP 6: Install lag bolt into the roof using a 1/2" socket drive until lag bolt is seated.



STEP 7: Slide channel nut to line up with the crown of tile.

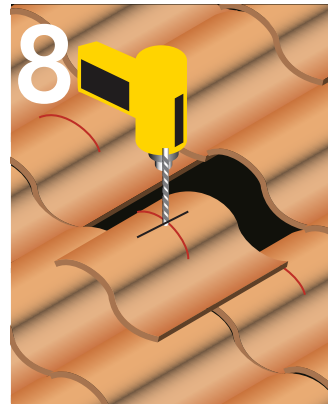

STEP 8: Using 3/8" carbide bit and a rotary hammer, drill through the crown of the tile at the intersection



STEP 9: Return tile back to place.

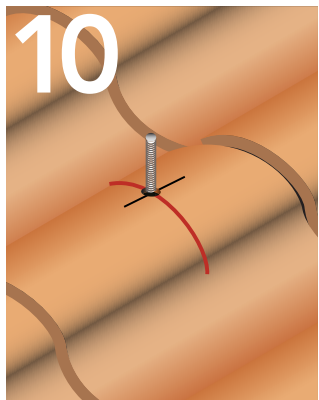

STEP 10: Insert and hand tighten threaded rod.

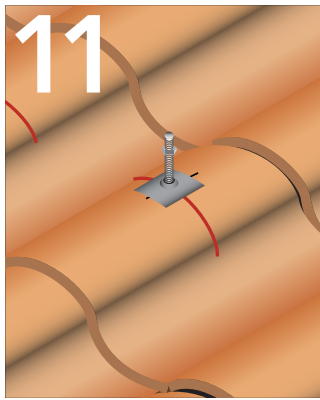

STEP 11: Using the provided flashing and two nuts to secure threaded rod. Tighten to 14 ft.-lbs. Caulk and seal around flashing and rod.

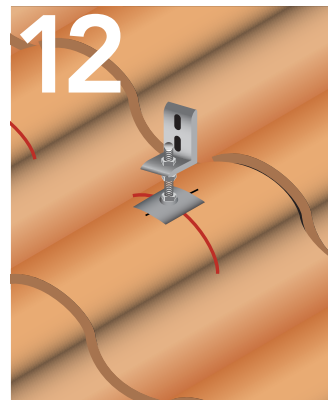

STEP 12: Use two flange nuts to hold L-bracket into place. Use Solar Mount rails to attach to L-brackets.



NOTE: Water and debris runs through the lowest point. Always attach threaded rod at the peak of the tile.

1.4.5 Flashed L-Feet Kit Installation

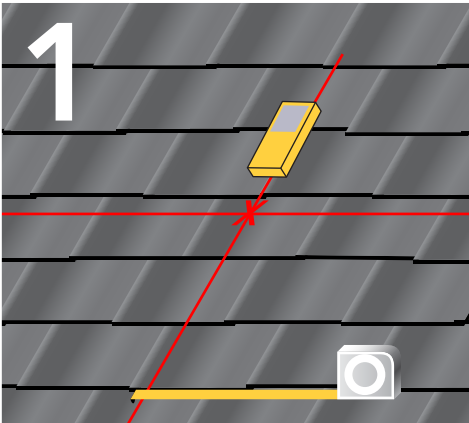

STEP 1: Locate the rafters and snap horizontal and vertical lines to mark installation position for each flashing.

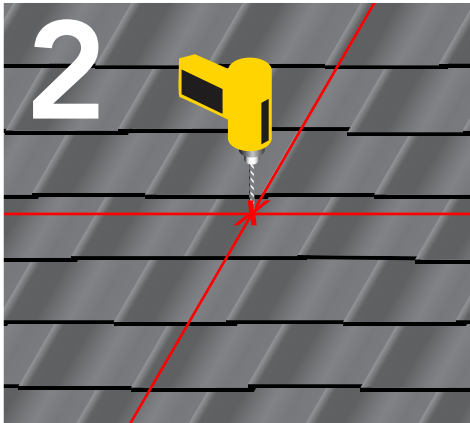

STEP 2: Drill a pilot hole (1/4" diameter) for the lag bolt. Backfill with sealant.

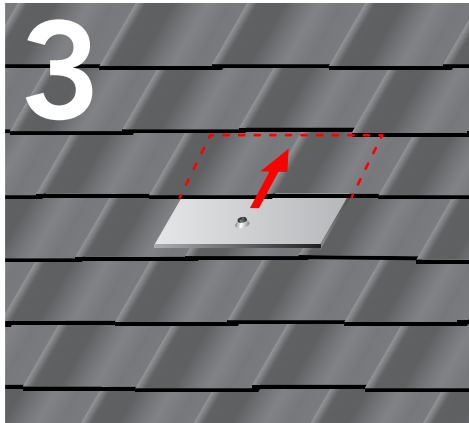

STEP 3: Insert the flashing so the top part is under the next row of shingles and pushed far enough up slope to prevent water infiltration through vertical joint in shingles. Line up flashing hole with pilot hole.

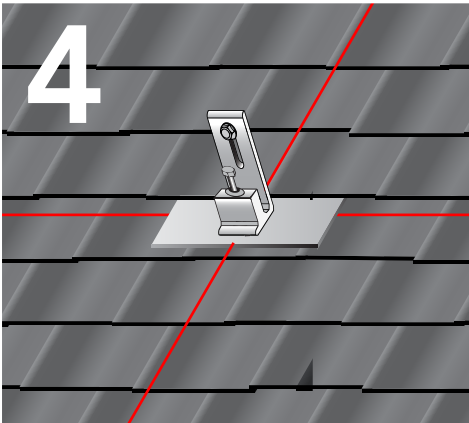

STEP 4: Line up pilot hole with high profile L-foot hole.

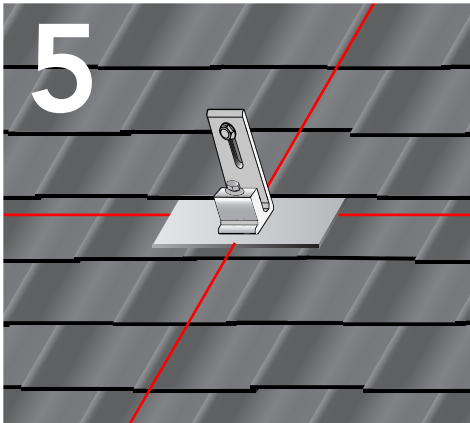

STEP 5: Insert lag bolt through L-feet, flashing and pilot hole.

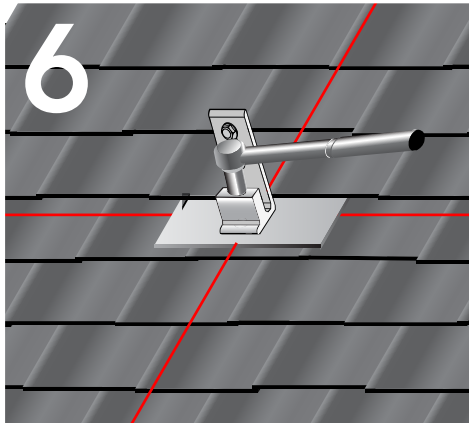

STEP 6: Tighten lag bolt to 100-140 inch pounds depending on the type of wood and time of year. If using an impact gun be careful to not over torque the fastener. You may need to stop and use a hand ratchet to finish the installation.



WARNING: Flashed L-foot products are NOT designed for and should NOT be used to anchor fall protection equipment.

1.4.6 Roof Bar Installation

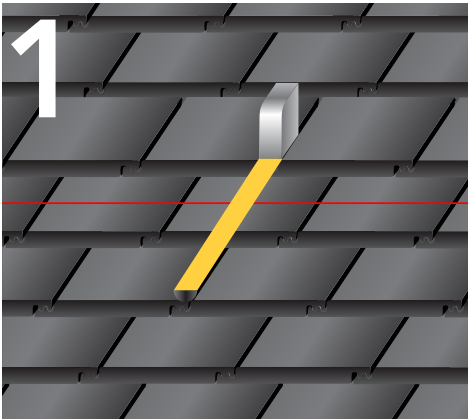

STEP 1: Snap horizontal line with chalk line.

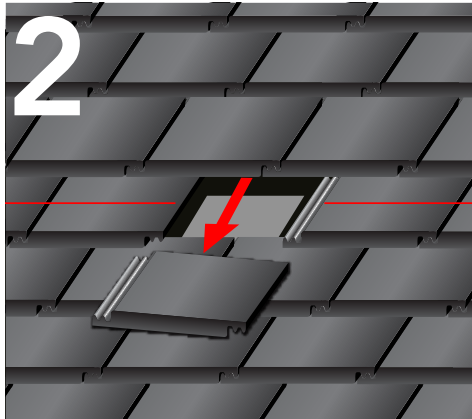

STEP 2: Remove tile.

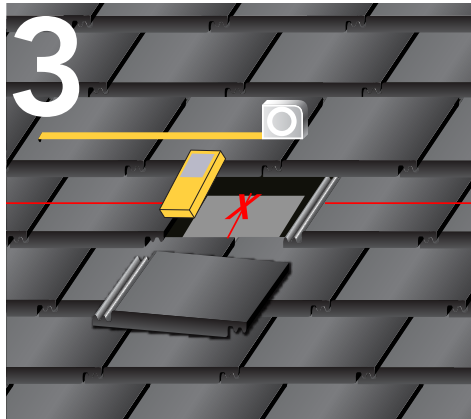

STEP 3: Use studfinder and measuring tape to find rafters.

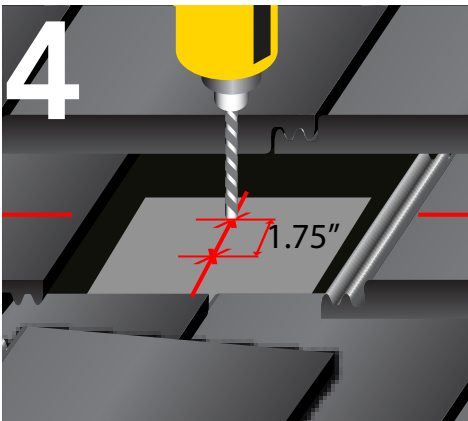

STEP 4: Drill two pilot holes (1/4" diameter) for the lag bolts 1.75" apart. Backfill with sealant.

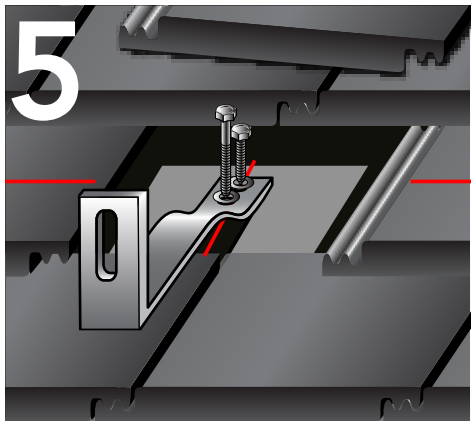

STEP 5: Line up pilot holes with roof bar holes.

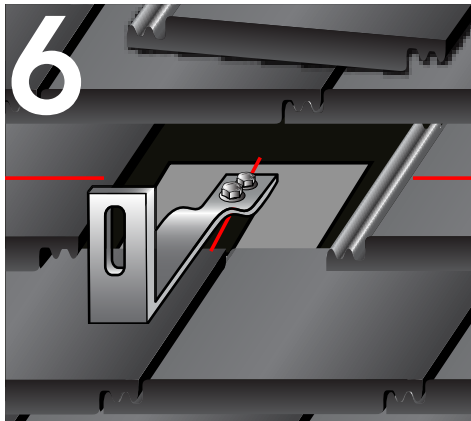

STEP 6: Insert lag bolts through 5/16" SS flat washers and into rafter.

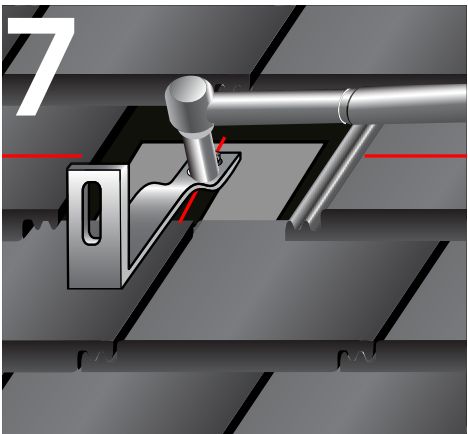

STEP 7: Tighten lag bolts using a 5/16" socket wrench to between 100-140 inch pounds depending on the type of wood and time of year.

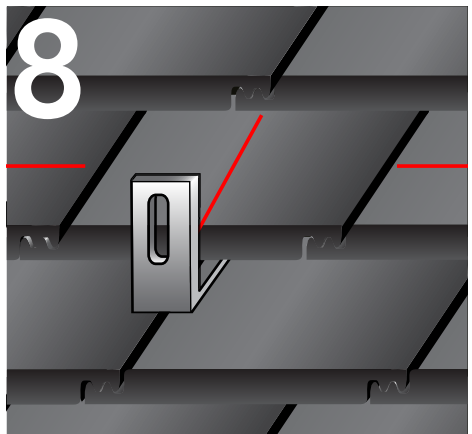

STEP 8: Reinstall tile. Underside of roof tile may have to be notched in order to seat flush onto roof bar.

1.4.7 Roof Hook Installation

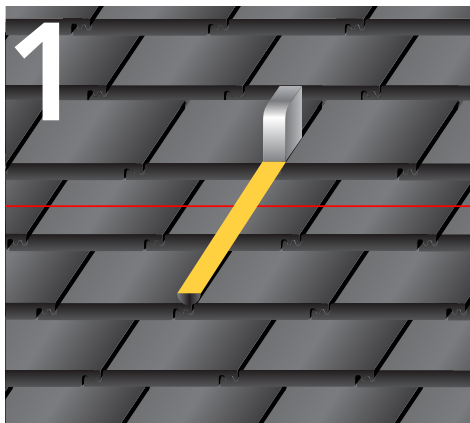

STEP 1: Snap horizontal line with chalk line.

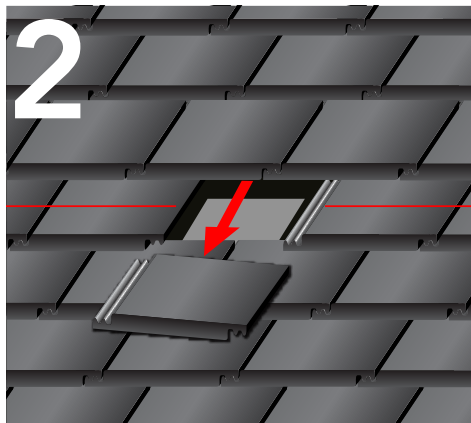

STEP 2: Remove tile.

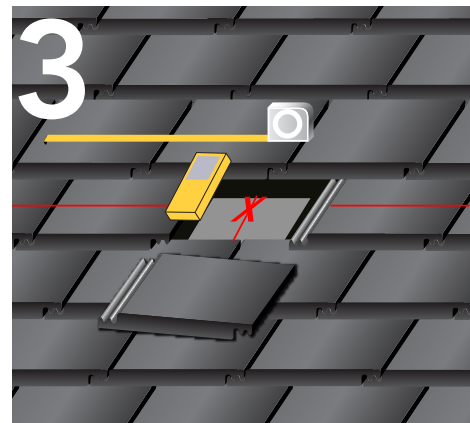

STEP 3: Use stud finder and measuring tape to find rafters

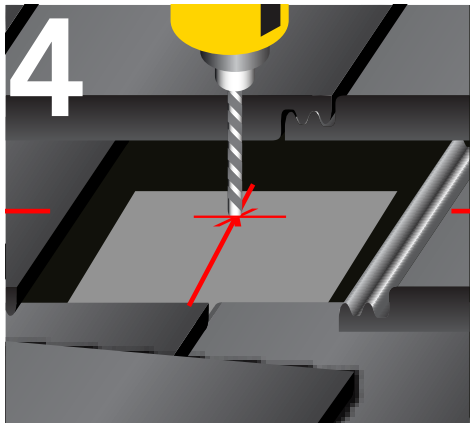

STEP 4: Drill a pilot hole (1/4" diameter). Backfill with sealant.

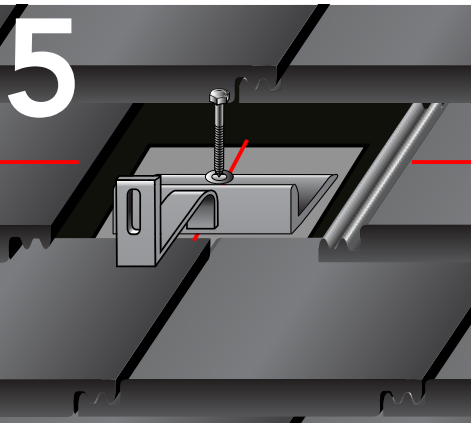

STEP 5: Line up pilot hole with roof bar holes

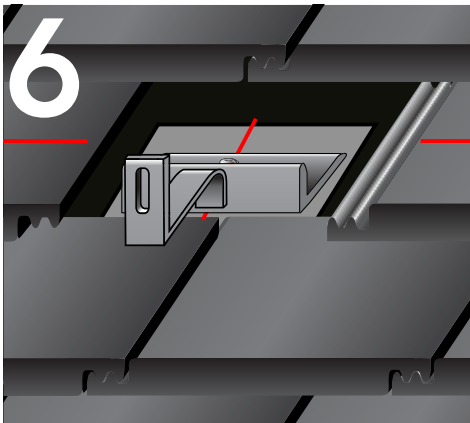

STEP 6: Insert lag bolt through 5/16" SS flat washer through roof hook and into the rafter.

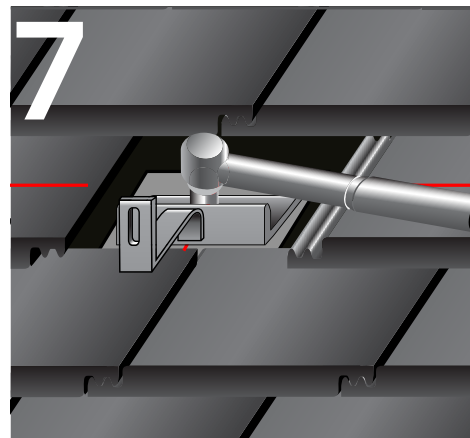

STEP 7: Tighten lag bolt using a 5/16" socket wrench to between 100-140 inch pounds depending on the type of wood and time of year.

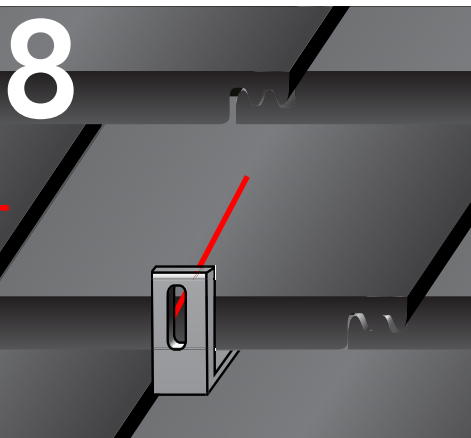

STEP 8: Reinstall Tile. Underside of roof tile may have to be notched in order to seat flush onto roof hook.

[3.2.8] Installing SWH rails and splices

Keep Rail slots free of roofing grit or other debris. Foreign matter will cause bolts to bind as they slide in the slots.

INSTALLING SPLICES: If your installation uses SWH splice bars or grounding splice plates, attach the rails together (**Fig. 12, 13**) before mounting the rails to the footings. Center of splice plate midpoint must align within a 1/8" gap maximum to ensure proper grounding.

Although structural, the joint is not as strong as the rail itself. A rail should always be supported by one footing on **BOTH** sides of the splice.

MOUNTING RAILS ON FOOTINGS: SWH Ecolite rails must use 2"x2" L-bracket only. SWH standard rail may be attached to either of two mounting holes in the L-bracket (**Fig. 14**). Mount in the lower hole for a low profile, more aesthetically pleasing installation. Mount in the upper hole for a higher profile, which will maximize airflow under the module. This will cool them and may enhance performance in the hotter climates. Slide 3/8" inch mounting bolts into the footing bolt slots. Loosely attach the rails to the footings with the flange nuts. Ensure that the rails are oriented to the footings as shown in **Figure 7,8,10,11** whichever is appropriate.

Expansion joints prevent buckling of rails due to thermal expansion. Splice bars or grounding splice plates may be used for thermal expansion joints. To create a thermal expansion joint, slide the splice bar or splice plate in the footing slots of both rail lengths, and leave approximately 1/2" between the rail segments. Secure the splice bar or splice plate with two screws or one bolt on one side only (**Fig.15**). Footings (such as L-feet or standoffs) should be secured normally on both sides of the splice. No PV module or mounting hardware components should straddle the expansion joint. Modules must clearly end before the joint with mounting hardware terminating on that rail. T-bolts should not be placed less than a distance of 1" from the end of the rail regardless of a splice with the exception of the high profile mode installation for the trim. The next set of modules would then start after the splice with mounting hardware beginning on the next rail.

A thermal break is required every 40 feet of continuous connected rail. For additional concerns on thermal break in your specific project, please consult a licensed structural engineer.

Bonding connections with splice used as thermal break - Options shown use two SWH grounding bolts or SWH grounding lugs and solid copper wire, or SWH splice jumper.

Figure 15. BONDING EXPANSION JOINT



Figure 12. SPLICE BAR ATTACHMENT FOR STANDARD RAILS ONLY

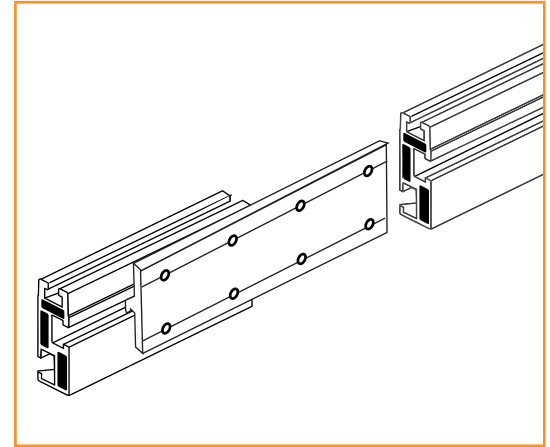

Figure 13. SPLICE PLATE ATTACHMENT FOR STANDARD OR ECOLITE RAILS

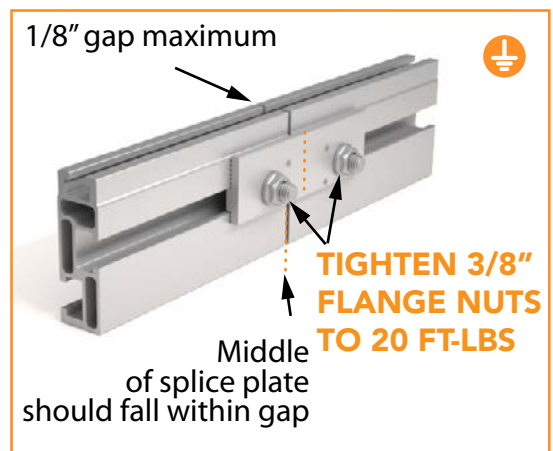
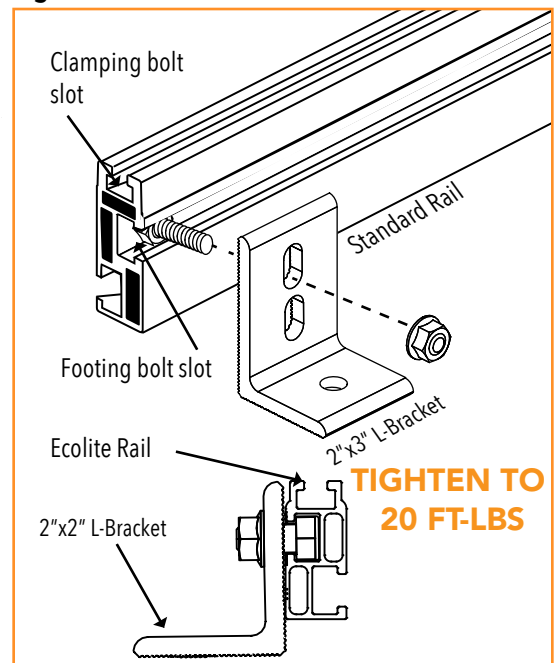

Figure 14. FOOT-TO-RAIL ATTACHMENT



1.4 Installing the modules

SAFETY- In high-profile installations, the best practice would be to install a safety stopper plate fastened to the footing bolt slot at the aligned (lower) end of each rail. It will prevent the lower end clamps and clamping bolts from sliding out of the rail slot during installation.

PRE-WIRING- If there is a return cable to the inverter, connect it to the first module. Close the J-box cover. (Fig.16)

FIRST MODULE- Secure the first module with T-bolts and either SWH grounding end clamp (Fig.17) or SWH standard end clamps (Fig.18) at the aligned end of each rail. Allow 1.5" distance between the rails ends and the end clamps. Finger tighten flange nuts, center and align the module as needed, and securely tighten the flange nuts.

You **MUST USE** the correct end size clamps for the corresponding modules thickness (Fig.19,20).

Please note: SWH standard end clamps (Fig.2 2), have been designed to tilt slightly inwards. Incorrect use will lead to structrue failure.

All SWH end clamps are intended for **MULTIPLE USES** at same or different module frame locations

Figure 16. Pre-wiring panels

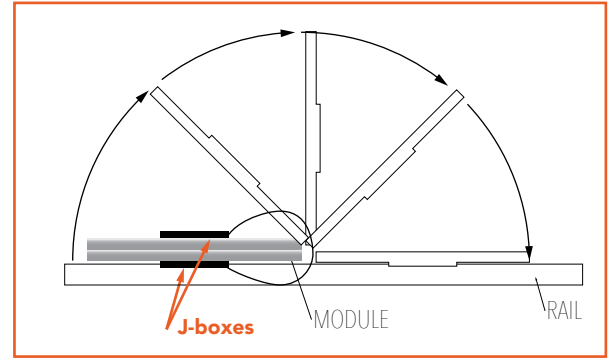

Figure 17. SWH grounding end clamp install

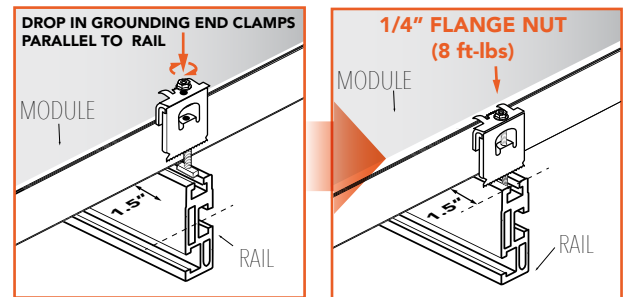

Figure 18. SWH standard end clamp install

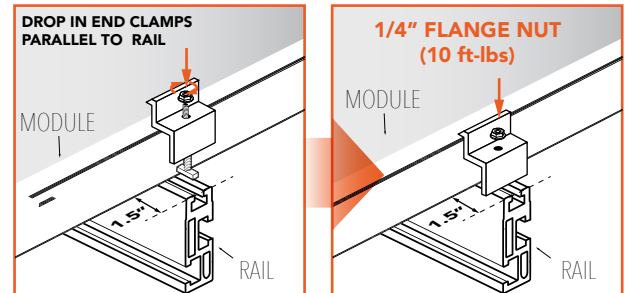

Figure 21. Check Grounding End Clamp Fit

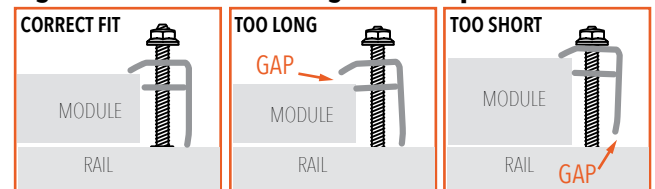

Figure 22. Check Standard End Clamp Fit

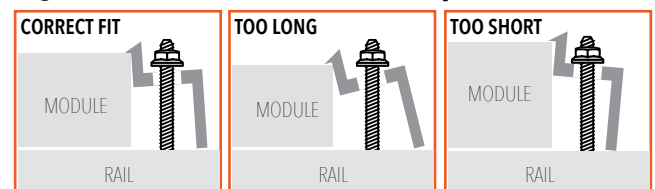

Figure 19. Grounding End Clamp Sizes

Part Name	Part Number	Module Height (mm)
"B" grounding end clamp	MR-SW-GEB-30	29-31
"C" grounding end clamp	MR-SW-GEC-35	34-36
"K" grounding end clamp	MR-SW-GEK-40	39-41
"F" grounding end clamp	MR-SW-GEF-45	44-46
"E" grounding end clamp	MR-SW-GEE-50	49-51

Figure 20. Standard End Clamp Sizes

Part Name	Part Number	Module Height (mm)
"C" end clamp	MR-SW-EC-35	34-36
"C" black end clamp	MR-SW-EC-35B	34-36
"K" end clamp	MR-SW-EK-40	39-41
"K" black end clamp	MR-SW-EK-40B	39-41
"F" end clamp	MR-SW-EF-45	44-46
"F" black end clamp	MR-SW-EF-45B	44-46
"E" end clamp	MR-SW-EE-50	49-51
"E" black end clamp	MR-SW-EE-50B	49-51

1.5.2 Installing the modules

SECOND MODULE- Place second module into position, leaving a 1/2" to 1-1/2" gap between it and the previous module. While holding module in place drop mid clamps into rail slots and rotate nuts to engage t-bolts.

Slide second module flush against the mid clamps. Once clamp teeth are in contact with both module frames and the bolts are properly aligned in slots, torque to 8 to 10 ft-lbs depending on the type of mid clamp. Repeat procedure for each following module.

You **MUST USE** the correct grounding mid clamp size for the corresponding module thickness (Fig. 23, 24).

You **MUST USE** same height modules for mid clamps to properly secure modules (Fig. 24, 25).

All SWH mid clamps are intended for **MULTIPLE USES** at same or different module frame locations.

Figure 23. Grounding Mid Clamp Sizes

Part Name	Part Number	Module Height (mm)	Grounding T-bolt length (mm)
"B" grounding mid clamp	EA-SW-GM-25B	<=32	50
"K" grounding mid clamp	EA-SW-GM-25K	33-42	60
"E" grounding mid clamp	EA-SW-GM-25E	43-51	70

Figure 24. Standard Mid Clamp Sizes

Part Name	Part Number	Module Height (mm)
Standard mid clamp (clear anodized)	MR-SW-MC-20	29-51
Standard mid clamp (black anodized)	MR-SW-MC-20B	29-51

Figure 25 Check Grounding Mid Clamp fit

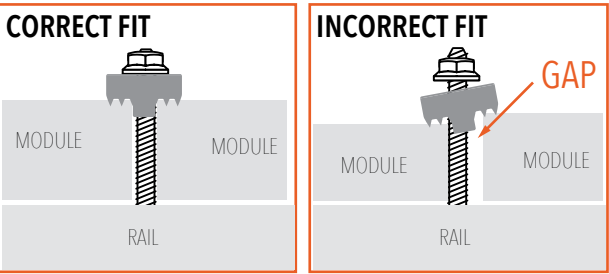
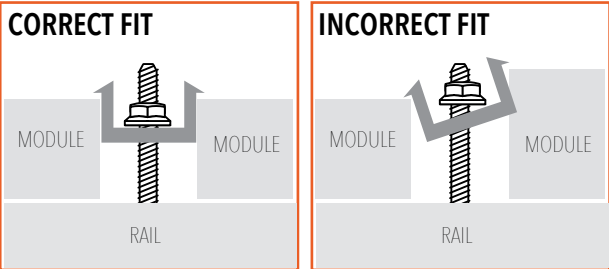
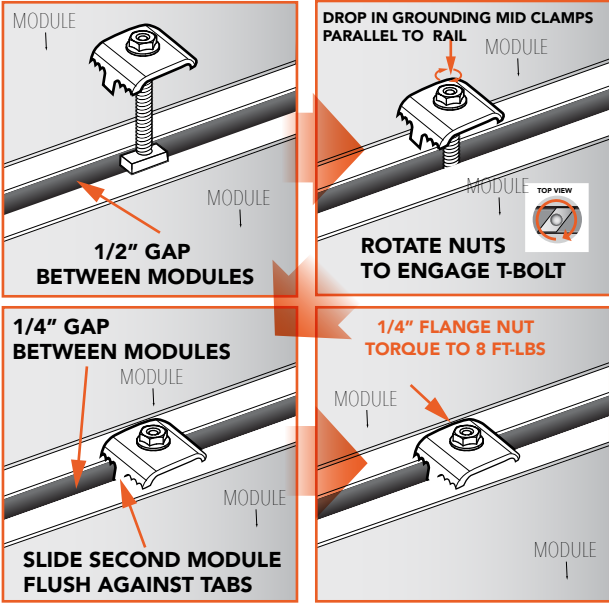

Figure 26. Check Standard Mid Clamp fit (Does not bond to module frame)



GROUNDING MID CLAMPS



STANDARD MID CLAMPS (Does not bond to module frame)

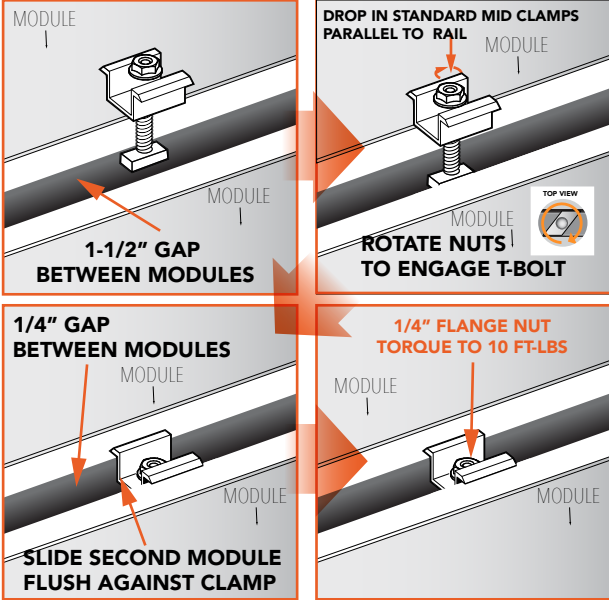

1.5.3 Grounding Path Diagram

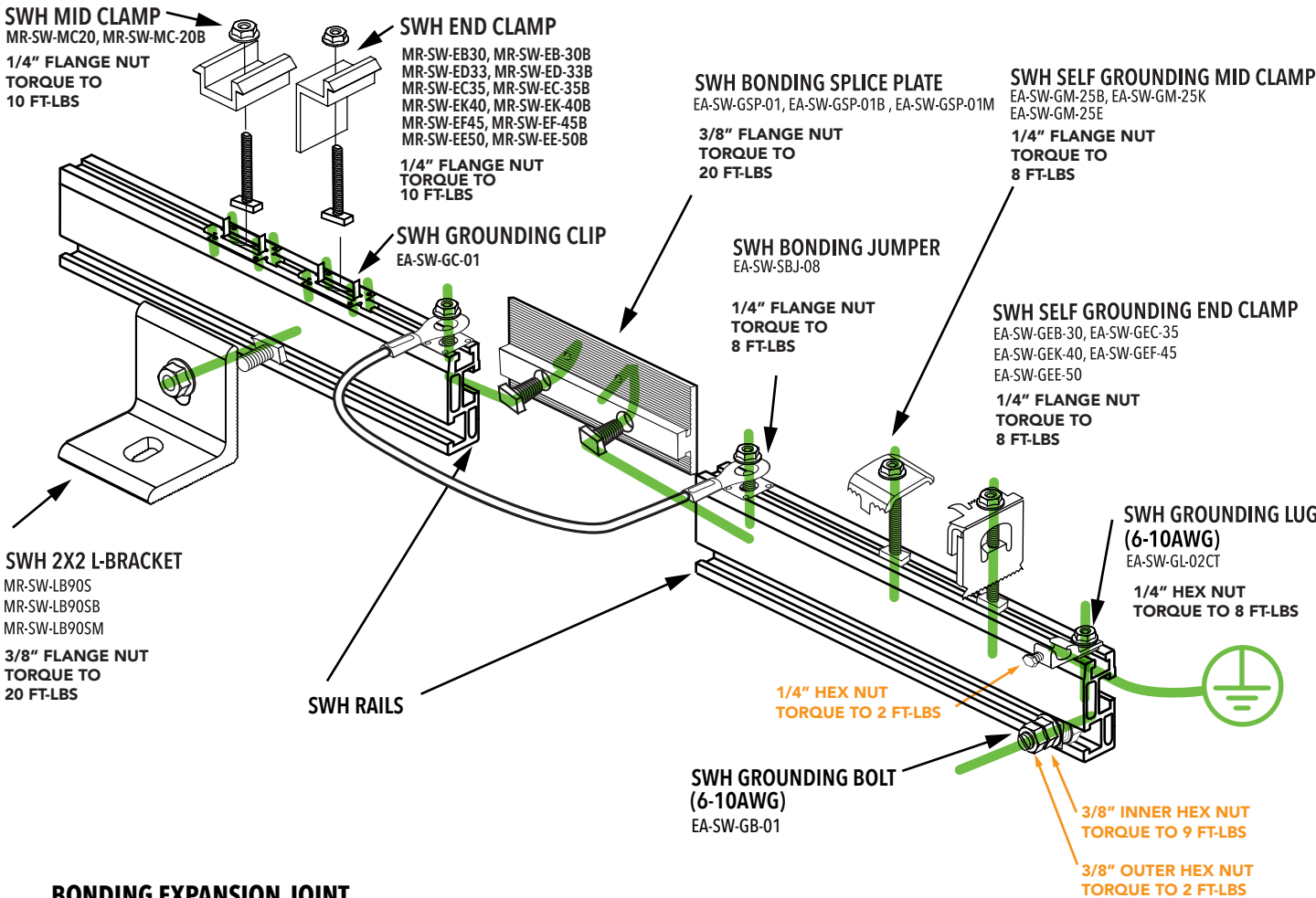

BONDING EXPANSION JOINT

! A thermal break is required every 40 feet of continuous connected rail. For additional concerns on thermal break in your specific project, please consult a licensed structural engineer.

Bonding connections with splice used as thermal break - Options shown use two SWH grounding bolts or SWH grounding lugs and shielded copper wire, or SWH splice jumper.

! Take care to prevent copper wires from directly contacting aluminum, as this will cause corrosion. The use of anti-oxidant grease is highly recommended to prevent ground wire terminal corrosion.

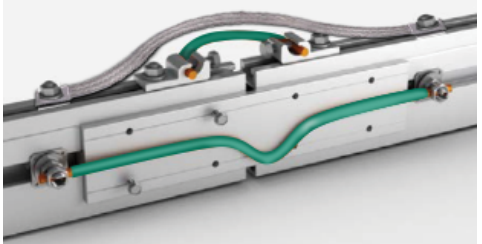





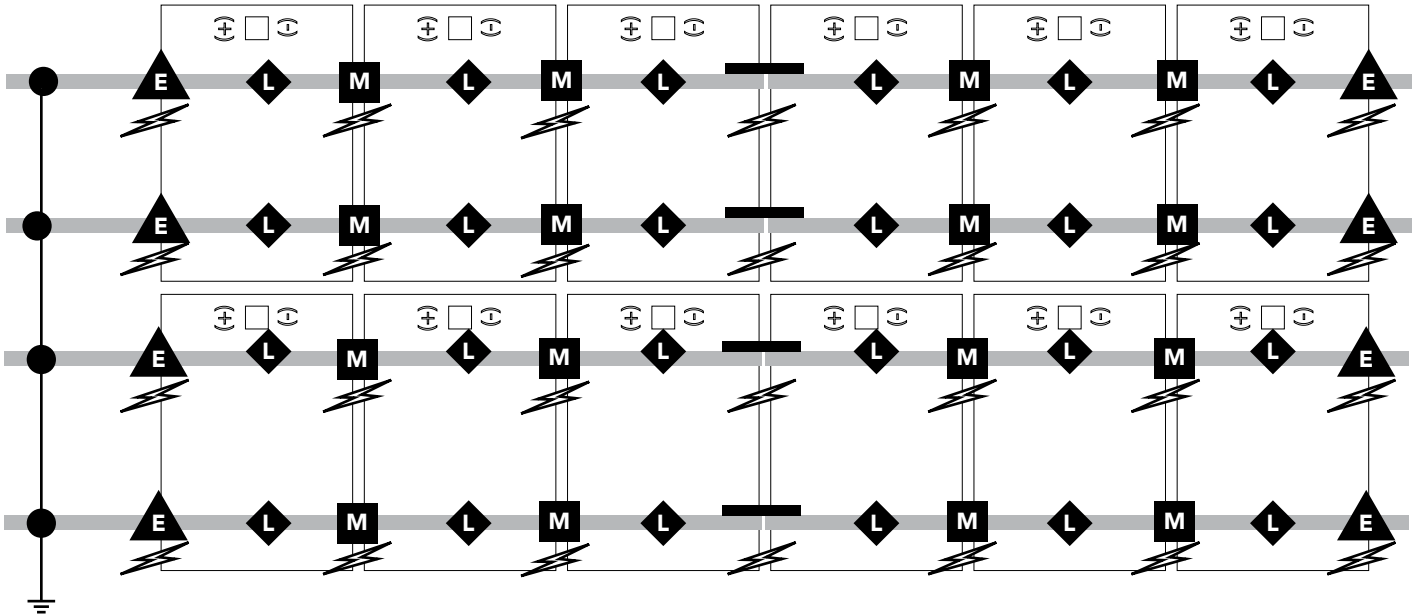

1/4" hardware* - Tighten to 8 ft-lbs
 *SWH Grounding lug- Tighten 1/4" wire terminal screw to 2 ft-lbs

3/8" hardware - Tighten to 20 ft-lbs**
 **SWH Grounding Bolt- Tighten INNER 3/8" hex nut to 9 ft-lbs
 - Tighten OUTER 3/8" hex nut to 2 ft-lbs

1.5.3 Grounding Path Diagram



-  SWH Bonding Splice Plate / SWH Splice Plate
-  SWH Self Grounding Mid Clamp
-  SWH Self Grounding End Clamp
-  SWH Grounding Lug / SWH Grounding Bolt
-  L bracket
-  SWH Standard Rail / SWH Ecolite Rail
-  Equipment Grounding Conductor

! BONDING EXPANSION JOINT

A thermal break is required every 40 feet of continuous connected rail. For additional concerns on thermal break in your specific project, please consult a licensed structural engineer.

Bonding connections with splice used as thermal break - Options shown use two SWH grounding bolts or SWH grounding lugs and shielded copper wire, or SWH splice jumper.

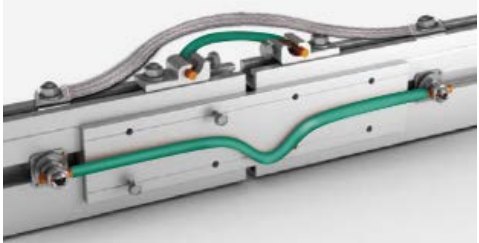

! Take care to prevent copper wires from directly contacting aluminum, as this will cause corrosion. The use of anti-oxidant grease is highly recommended to prevent ground wire terminal corrosion.

1.6 Installer Warning and Notice

NOTICE!

Please carefully read and understand the provided installation manual before installing, wiring, or operating our product in your PV system. Failure to follow all instructions and conditions could possibly damage the product and above all, lead to serious injury or death. **PV system and SWH Solar Racking installations must comply with National Electrical Code and installer is solely responsible for code and safety compliances and their consequences.**

WARNING!



**DANGER
Electric
shock risk**

PV modules generate electricity when exposed to light and are electrically live when mounted. This DC electricity can pose danger to the installer, user, and/or property. Any contact with electrically active module terminals can result in arcing; leading to shocks, fires, burns, and/or death. Use caution around utility power lines that may be near the work area. Never work in wet or windy conditions. Lighting is a hazard to any work with metal, never work when lighting is present. Insure good earth-bonding as part of a lighting protection system.

! DANGER!



Electrical shock potential of PV modules increases with higher parallel currents and series voltage connections. The PV installer must assume all inherent risk of property damage and/or personal injury related to the mishandling of PV modules during installation and maintenance. Skilled, Licensed Electricians must conduct all electrical installation procedures. All work must comply with all national, state and local installation procedures, product and safety standards. These standards include but are not limited to applicable National Electrical Code (NEC®) sections, UL Standards, OSHA Regulations, State or Local Fire Marshall Codes, NFPA 70E. Installation must comply with NEC 250 (Grounding and Bonding), NEC 690 (Solar Photovoltaic Systems), CSA 22.1 (Safety Standard for Electrical Installations), Canadian Electrical Code Part 1, and all other applicable state, provincial, and local electrical code requirements. **SWH Solar Racking Systems** must be used with UL1703 listed equipment including but not limited to; PV modules, combiners and disconnects.

Installer shall ensure all warning labels requirements are met per latest National Electrical code (NEC), International Fire Code (IFC), and/or Cal Fire Code.

! DANGER!



Avoid electrical injuries by preventing the accidental or unintentional release of hazardous energy. Proper Lockout/Tag out procedures will limit this danger. All Personnel must use caution when working in and around PV arrays. Proper PPE worn at all times will also limit this danger. Modules produce electricity when exposed to light. To avoid electric shock and injury, completely cover the front of the module with an opaque material before making any electrical connections. Lock out / tag out and disconnect the PV system from all electrical energy before any maintenance or cleaning. NEVER disconnect or connect modules under load. Never disconnect the earth bond to the array.

1.6 Installer Warning and Notice

DANGER!



When installing SWH Solar Racking Systems on roofs a falling hazard is present. Proper fall protection will limit this danger. Never work in wet or windy conditions. Secure tools and materials from falling, and insure personnel below exercise caution from work overhead. Follow all OSHA guidelines for working on roofs, with ladders, and insure general safety conditions exist.

DANGER!



DANGER
Electric
shock risk

The Installer of **SWH Solar Racking Systems** must provide the components necessary for the final connections to the grounding electrode system. Typically the installation will incorporate a grounding electrode (ground rod), appropriately sized copper wire, rated wire connectors, and grounding lugs which are out-door rated for this purpose. Many PV installations contain more than one mounting array. Such cases call for electrically bonding each of the different arrays together. It is only necessary to connect individual racks together from one single point to another single point. Only use stainless steel hardware when connecting harnesses or jumpers to the mounting system.

Take care to prevent copper wires from directly contacting aluminum, as this will cause corrosion. The use of anti-oxidant grease is highly recommended to prevent ground wire terminal corrosion.

Use mechanically sound methods to secure ground/ bond wires to **SWH Solar Racking Systems** thus ensuring electrical continuity at all times. Conductors must meet or exceed the requirements of the NEC. Always refer to your local AHJ (Authority Having Jurisdiction) when sizing conductors, fuses, inverters, and other Balance of System (BOS) components. Where common grounding hardware (nuts, bolts, star washers, spilt-ring lock washers, flat washers and the like) are used to attach a listed grounding/bonding device, the attachment must be made in conformance with the grounding device manufacturer's instructions.

1.7 Mechanical Loading Specifications and Module Compatibility

To be used only in combination with modules that include this specific rack system in their installation manual.

PV Modules Mechanically Load and Grounding/Bonding Tested per UL 2703 Ed. 1 (2015) Standard

(XXX denotes module power rating and includes both black and silver frames)

Tested Modules			Design Load Ratings		
Module Manufacturer	Model Number	Surface Area (sf)	Downward Pressure Test Load (psf)	Upward Pressure Test Load (psf)	Downslope Test Load (psf)
Canadian Solar	CS6X-XXXP	20.67	10	5	5
Hyundai	HiS-SXXXRG	17.62	10	5	5
LG Electronics	LGXXS1C-G4	17.65	10	5	5
SolarWorld	Sunmodule Plus	18.05	10	5	5
Sunpower	SW XXX Mono SPR-E20-XXX	17.54	10	5	5

*Module Orientation: Portrait or Landscape *Maximum Module Size: 24 ft²

*Maximum Number of Modules: 30 x10 (Landscape); 50 x 6 (Portrait), a total of 300 max

Compatible PV Modules Grounding/Bonding Evaluated

(XXX denotes module power rating and includes both black and silver frames)

Evaluated Modules

Manufacturer	Model numbers
Canadian Solar	CS6K-XXXMS, CS6K-XXXM, CS6K-XXXP, CS6P-XXXP, CS6U-XXXM, CS6U-XXXP, CS6X-XXXP.
CSUN	CSUNXXX-72M
Ecosolargy	ECOXXXT156M-60, ECOXXXH156p-72
ET Solar	ET-P660XXXWX
Hanwha Q Cell	Q.PEAK-G4.1 XXX, Q.PEAK BLK-G4.1 XXX
Hyundai	HiS-MXXXMF, HiS-SXXXMF, HiS-MXXXMG, HiS-SXXXMG, HiS-MXXXRG, HiS-SXXXRG.
JA Solar	JAP6(K)-60XXX/4BB
Japan Solar	JS-XXXM-LI72
Jinko Solar	JKMXXXPP-60
LG Electronics	LGXXXN1C-G4, LGXXXN1K-G4, LGXXS1C-G4.
Mission Solar	MSEXXSQ5T
Panasonic	VBHNXXXSA16
Peimar	SGXXXP
REC Solar	RECXXT2P
Silfab	SLA-MXXX
Solaria	PowerXT XXXR-XX
SolarWorld	Sunmodule Bisun SW XXX duo, Sunmodule Pro-Series SW XXX Poly Wob, Sunmodule Protect SW XXX Mono Black, Sunmodule SW XXX XL Mono, Sunmodule Plus SW XXX Mono.
Sunpower	SPR-X21-XXX, SPR-E20-XXX.
Talesun	TP660P XXX
Trina Solar	TSM-DD05A.0X(II) XXX



MANUFACTURER'S LIMITED STRUCTURAL PERFORMANCE WARRANTY

Solar Warehouse warrants to the buyer ("Buyer") at the original installation site ("Site") that any of the components (the "Product") purchased from Solar Warehouse shall be free from structural defects in material, workmanship and performance, as referenced in the Solar Warehouse Product Information, for a period of ten (10) years, except for the anodized finish, in which the finish shall be free from visible peeling, cracking or chalking under normal atmospheric conditions for a period of five (5) years ("Finish Warranty"), from the earlier of 1) the date in which the installation of the product on site was substantially completed, or 2) 120 days after the purchase of the Product by the original Buyer of the Product ("Warranty Period"). Buyer may transfer this Warranty to subsequent owners, or if Buyer is a contractor to the property owner. In this Warranty, the term "Buyer" refers to the original buyer and any subsequent transferee of which Solar Warehouse has advance notice. Proof of purchase is required. The Finish Warranty does not apply to any foreign residue deposited on the finish. All installations in corrosive atmospheric conditions are excluded. The Finish Warranty is VOID if the practices specified by AAMA 609 & 610-02 – "Cleaning and Maintenance for Architecturally Finished Aluminum" (www.aamanet.org) are not followed by Purchaser. This Limited Warranty covers only the Product, and not PV modules, electrical components and/or wiring used in connection with the Product or any other materials not provided by Solar Warehouse. This Warranty does not cover damage to the Product that occurs during its shipment, storage, and installation, or from any force majeure acts including fire, flood, earthquake, storm, hurricane or other natural disaster, war, terrorist activities, acts of foreign enemies and criminal acts. This Limited Warranty shall be void if, A) installation of the Product is not performed in accordance with the Solar Warehouse Product Information, B) if the Product has been modified, repaired, or reworked in a manner not previously authorized by Solar Warehouse in writing, or C) the Product is installed in an environment for which it was not designed, each as determined by Solar Warehouse, at Solar Warehouse's sole discretion. If, within the Warranty Period, the Product shall be proven in Solar Warehouse sole discretion to be defective, then Solar Warehouse shall repair or replace the defective Product, or any part thereof, at Solar Warehouse's option. Any such repair or replacement does not cause the beginning of new warranty terms, nor shall the Warranty Period of this Limited Warranty be extended. Solar Warehouse's aggregate liability under this Limited Warranty shall not exceed the original Purchase Price of the Product. Buyer shall bear all costs of shipment or transportation related to the repair or replacement of the defective product. Such repair or replacement shall be Buyer's sole remedy under this Limited Warranty and shall fulfill all of Solar Warehouse's obligations with respect to this Limited Warranty. EXCEPT FOR THE LIMITED WARRANTY EXPRESSED ABOVE, SOLAR WAREHOUSE MAKES NO REPRESENTATION OR WARRANTY OF ANY KIND WHATSOEVER AND HEREBY DISCLAIMS ALL OTHER WARRANTIES, EXPRESS OR IMPLIED, INCLUDING THE IMPLIED WARRANTIES OF MERCHANTABILITY, FITNESS FOR A PARTICULAR PURPOSE, COURSE OF DEALING AND USAGE OF TRADE.

SOLAR WAREHOUSE SHALL NOT BE LIABLE FOR LOSS OF USE, REVENUE OR PROFIT, OR FOR INDIRECT, SPECIAL, PUNITIVE, LIQUIDATED, INCIDENTAL OR CONSEQUENTIAL DAMAGES, OR FOR ANY OTHER LOSS OR COST OF A SIMILAR TYPE, OR FOR CLAIMS BY BUYER FOR DAMAGES OF BUYER'S CUSTOMERS, CLAIMS OF A SIMILAR TYPE, OR FOR CLAIMS BY BUYER FOR DAMAGES OF BUYER'S CUSTOMERS, CLAIMS OF THIRD PARTIES OR INJURY TO PERSONS OR PROPERTY ARISING OUT OF ANY DEFECT IN THE PRODUCT COVERED BY THIS WARRANTY. ALL SUCH DAMAGES AND EXPENSES ARE HEREBY EXCLUDED.

For warranty service claims, please contact Solar Warehouse at info@esolarwarehouse.com