

## SWH Solar Mount Roof Hook

Part No. MR-SW-RF5.8LPB, MR-SW5.8LP

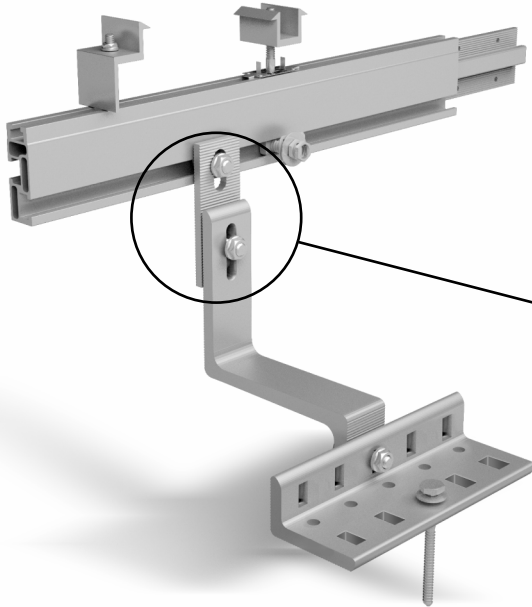

**Roof hook material:** 6005-T5 extruded aluminum alloy

**Finish:** Clear or black anodized

**Bolt & nut material:** 304 stainless steel

**Roof hook weight:** 0.674 lbs

Attach Roof Hook Part A to Part B with one 5/16" x 1" carriage bolt and one 5/16" ASTM F594 serrated flange nut.

**Optional Extension Plate:** MR-SW-EP-32, MR-SW-EP-32B

1.2"W X 3.2"H SS 3/8" X 1" hex bolts and flange nuts

**CONFORMS TO  
UL 2703**

**ETL CLASSIFIED**



**Intertek  
4009330**

**Optional Sub Flashing:** MR-SW-RF140906G-

14"W X 9"D X 1"H Galvanized Steel Roof Sub-Flashing, Mill Finish

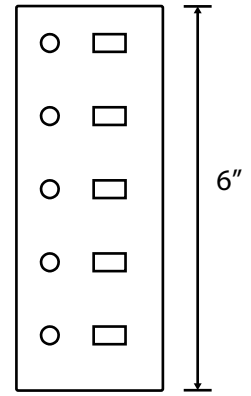
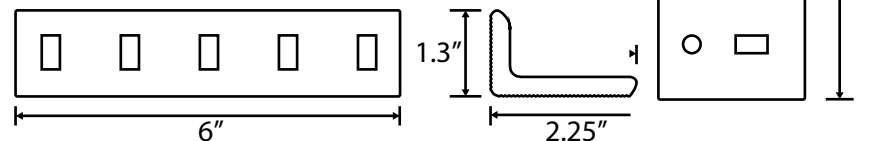
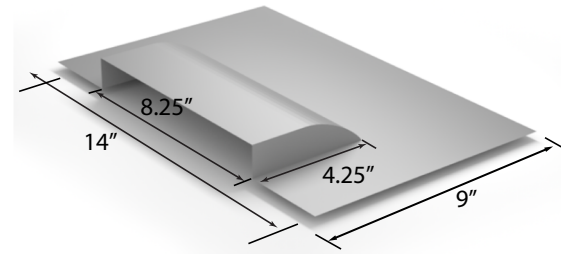
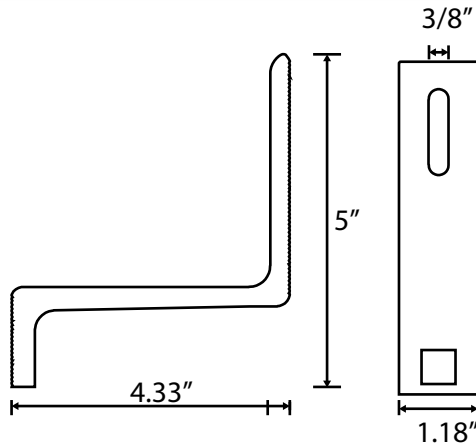

**Table 11: Lag- pull-out (withdrawal) capacities (lbs) in typical roof lumber (ASD)**

Sources: American Wood Council, NDS 2018, Table 12.2A and 12.3.3A.

Courtesy, American Wood Council, Leesburg, VA.

**AWC Table 12.2A Lag Screw Reference Withdrawal Values, W<sup>1</sup>**

Tabulated withdrawal design values (W) are in pounds per inch of thread penetration into side grain of wood member. Length of thread penetration in main member shall not include the length of the tapered tip (see 12.2.1.1).

Specific Gravity, G <sup>2</sup>	Lag Screw Diameter, D										
	1/4"	5/16"	3/8"	7/16"	1/2"	5/8"	3/4"	7/8"	1"	1-1/8"	1-1/4"
0.73	397	469	538	604	668	789	905	1016	1123	1226	1327
0.71	381	450	516	579	640	757	868	974	1077	1176	1273
0.68	357	422	484	543	600	709	813	913	1009	1103	1193
0.67	349	413	473	531	587	694	796	893	987	1078	1167
0.58	281	332	381	428	473	559	641	719	795	869	940
0.55	260	307	352	395	437	516	592	664	734	802	868
0.51	232	274	314	353	390	461	528	593	656	716	775
0.50	225	266	305	342	378	447	513	576	636	695	752
0.49	218	258	296	332	367	434	498	559	617	674	730
0.47	205	242	278	312	345	408	467	525	580	634	686
0.46	199	235	269	302	334	395	453	508	562	613	664
0.44	186	220	252	283	312	369	423	475	525	574	621
0.43	179	212	243	273	302	357	409	459	508	554	600
0.42	173	205	235	264	291	344	395	443	490	535	579
0.41	167	198	226	254	281	332	381	428	473	516	559
0.40	161	190	218	245	271	320	367	412	455	497	538
0.39	155	183	210	236	261	308	353	397	438	479	518
0.38	149	176	202	227	251	296	340	381	422	461	498
0.37	143	169	194	218	241	285	326	367	405	443	479
0.36	137	163	186	209	231	273	313	352	389	425	460
0.35	132	156	179	200	222	262	300	337	373	407	441
0.31	110	130	149	167	185	218	250	281	311	339	367

1. Tabulated withdrawal design values, W, for lag screw connections shall be multiplied by all applicable adjustment factors (see Table 11.3.1).  
2. Specific gravity, G, shall be determined in accordance with Table 12.3.3A.

**AWC Table 12.3.3A Assigned Specific Gravities**

Species Combination	Specific Gravity, G	Species Combinations of MSR and MEL Lumber	Specific Gravity, G
Alaska Cedar	0.47	Douglas Fir-Larch	0.50
Alaska Hemlock	0.46	EP=1,000 psi and lower grades of MSR	0.50
Alaska Spruce	0.41	EP=2,000 psi grades of MSR	0.51
Alaska Yellow Cedar	0.46	EP=1,000 psi grades of MSR	0.52
Aspen	0.39	EP=2,000 psi grades of MSR	0.53
Balsam Fir	0.36	EP=2,000 psi grades of MSR	0.54
Beech-Birch-Hickory	0.71	EP=400,000 psi grades of MSR	0.55
Coastal Spruce	0.39	Douglas Fir-Larch (North)	0.49
Conifer	0.41	EP=1,000 psi and lower grades of MSR and MEL	0.49
Douglas Fir-Larch	0.50	EP=1,000 psi and higher grades of MSR and MEL	0.53
Douglas Fir-Larch (North)	0.49	EP=2,000 psi and higher grades of MSR and MEL	0.57
Douglas Fir (South)	0.46	EP=1,000 psi grades of MSR	0.54
Eastern Hemlock	0.41	EP=1,000 psi and higher grades of MSR	0.46
Eastern Hemlock-Balsam Fir	0.36	Engelmann Spruce-Lodgepole Pine	0.38
Eastern Hemlock-Tamarack	0.41	EP=1,000 psi and lower grades of MSR	0.46
Eastern Hemlock-Tamarack (North)	0.47	EP=1,000 psi and higher grades of MSR	0.46
Eastern Softwoods	0.36	Hem-Fir	0.43
Eastern Spruce	0.41	EP=1,000 psi and lower grades of MSR	0.43
Eastern White Pine	0.34	EP=600,000 psi grades of MSR	0.44
Engelmann Spruce-Lodgepole Pine	0.38	EP=1,700,000 psi grades of MSR	0.45
Hem-Fir	0.41	EP=1,000 psi grades of MSR	0.46
Hem-Fir (North)	0.46	EP=900,000 psi grades of MSR	0.47
Mixed Maple	0.55	EP=2,000 psi grades of MSR	0.48
Mixed Oak	0.68	EP=2,000 psi grades of MSR	0.49
Mixed Southern Pine	0.51	EP=2,000 psi grades of MSR	0.50
Moisture Hemlock	0.47	EP=1,000 psi grades of MSR	0.51
Northern Pine	0.42	EP=2,000 psi grades of MSR	0.52
Northern Red Oak	0.68	Hem-Fir (North)	0.46
Northern Spruce	0.39	EP=1,000 psi and higher grades of MSR and MEL	0.46
Northern White Cedar	0.31	Southern Pine	0.51
Piedmont Pine	0.43	EP=1,000 psi and lower grades of MSR and MEL	0.55
Red Maple	0.58	EP=1,000 psi and higher grades of MSR and MEL	0.57
Red Oak	0.67	Spruce-Pine-Fir	0.42
Red Pine	0.44	EP=1,000 psi and lower grades of MSR and MEL	0.43
Radiata Pine	0.37	EP=1,000 psi and 1,900,000 psi grades of MSR and MEL	0.46
Sitka Spruce	0.40	EP=2,000 psi and higher grades of MSR and MEL	0.50
Southern Pine	0.52	Spruce-Pine-Fir (North)	0.36
Spruce-Pine-Fir	0.42	EP=1,000 psi and lower grades of MSR	0.42
Spruce-Pine-Fir (North)	0.36	EP=1,000 psi and 1,900,000 psi grades of MSR	0.42
Western Cedars	0.36	EP=2,000 psi and higher grades of MSR	0.50
Western Cedars (North)	0.35	Western Cedars	0.36
Western Hemlock	0.47	EP=1,000 psi and higher grades of MSR	0.36
Western Hemlock (North)	0.46	Western White Pine	0.40
Western Juniper	0.42	EP=1,000 psi and higher grades of MSR	0.36
Western White Pine	0.40		
Western White Pine	0.38		
White Oak	0.73		
Yellow Poplar	0.40		

1. Specific gravity, G, based on weight and volume when oven-dry. Different specific gravities, G, are possible for different grades of MSR and MEL lumber (see Table 4-C, Footnote 2).